

TM 10-5430-256-13&P

TECHNICAL MANUAL

**OPERATOR AND FIELD LEVEL
MAINTENANCE MANUAL INCLUDING REPAIR PARTS AND
SPECIAL TOOLS LIST (RPSTL)
FOR**

**3K & 5K SEMI-TRAILER MOUNTED FABRIC TANK (SMFT)
WATER, COLLAPSIBLE**

MODELS

**GTA-3K-SMFT
(NSN 5430-01-564-7919)**

**GTA-5K-SMFT
(NSN 5430-01-564-7916)**

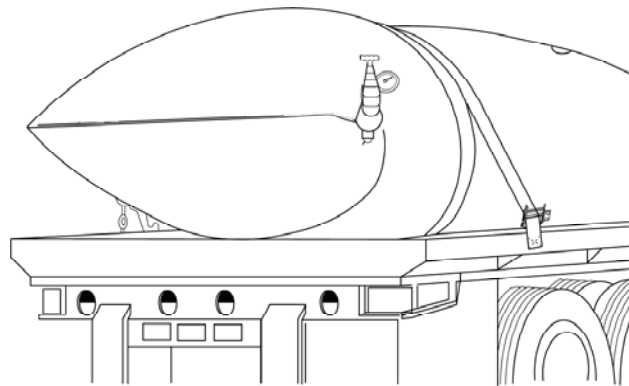

DISTRIBUTION STATEMENT A: Approved for public release; distribution is unlimited.

HEADQUARTERS, DEPARTMENT OF THE ARMY

APRIL 2009

WARNING SUMMARY

This warning summary contains general safety warnings and hazardous materials warnings that must be understood and applied during operation and maintenance of this equipment. Failure to observe these warnings could result in serious injury or death to personnel.

FIRST AID

FOR ARTIFICIAL RESPIRATION, REFER TO FM 4-25.11, First Aid.

EXPLANATION OF SAFETY WARNING ICONS



Explosion – rapid expanding shows that material may rupture if subjected to high pressure.



Poison – skull and crossbones shows that a material is poisons or is a danger to life.

GENERAL SAFETY WARNING DESCRIPTION



The tank can only be transported full or empty. A partially filled tank being transported will result in load shifting (surge) and will result in reduction of vehicle control and possible rupture of the tank wall, resulting in serious injury or death.



Use tank for drinking water only. Other liquids will contaminate tank and could cause personal injury.



Do not overfill tank. Ensure filling assembly coupling is installed correctly or the tank/coupling may burst and cause personal injury.



The tank is drained by gravity or suction pump only. Use of air pressure to unload tank is not authorized as it may cause the tank to burst under pressure.



Do not air test tank. Over pressurization could cause tank to burst, resulting in serious injury or death.



Use lifting device capable of lifting 1000 lbs. to prevent injury or death to personnel.



The solvent and adhesive furnished in the repair kit are highly flammable and toxic to the skin, eyes and respiratory tract. Skin/eye protection is required. Avoid prolonged breathing of vapors and minimize skin contact. Keep away from excessive heat, open flame or other sources of ignition. Failure to observe these precautions may result in death or serious injury to personnel.



Clean parts in a well-ventilated area. Avoid inhalation of solvent fumes and prolonged exposure to cleaning solvent. Wash exposed skin thoroughly. Solvent used to clean parts is potentially dangerous to personnel and property. Do not use near open flame or excessive heat.



LIST OF EFFECTIVE PAGES/WORK PACKAGES

NOTE: Zero in the "Change No." column indicates an original page or work package.

Date of issue for the original manual is:

Original 15 April 2009

TOTAL NUMBER OF PAGES FOR FRONT AND REAR MATTER IS 22 AND TOTAL NUMBER OF WORK PACKAGES IS 34 CONSISTING OF THE FOLLOWING:

Page/WP No.	Change No.	Page/WP No.	Change No.
Front Cover	0	Chp 6 title page	0
Blank	0	Blank	0
Warning Summary (2 pgs)	0	WP 0018 (6 pgs)	0
i-iii/iv blank		WP 0019 (4 pgs)	0
Chp 1 title page	0	WP 0020 (4 pgs)	0
Blank	0	WP 0021 (4 pgs)	0
WP 0001 (2 pgs)	0	WP 0022 (4 pgs)	0
WP 0002 (4 pgs)	0	WP 0023 (4 pgs)	0
WP 0003 (2 pgs)	0	WP 0024 (4 pgs)	0
Chp 2 title page	0	WP 0025 (4 pgs)	0
Blank	0	WP 0026 (4 pgs)	0
WP 0004 (2 pgs)	0	WP 0027 (2 pgs)	0
WP 0005 (6 pgs)	0	WP 0028 (2 pgs)	0
WP 0006 (2 pgs)	0	Chp 7 title page	0
Chp 3 title page	0	Blank	0
Blank	0	WP 0029 (2 pgs)	0
WP 0007 (6 pgs)	0	WP 0030 (4 pgs)	0
WP 0008 (6 pgs)	0	WP 0031 (2 pgs)	0
Chp 4 title page	0	WP 0032 (6 pgs)	0
Blank	0	WP 0033 (2 pgs)	0
WP 0009 (2 pgs)	0	WP 0034 (2 pgs)	0
WP 0010 (4 pgs)	0	INDEX-1 – INDEX-4	0
WP 0011 (4 pgs)	0	Inside Back Cover	0
Chp 5 title page	0	Back Cover	0
WP 0012 (16 pgs)	0		
WP 0013 (6 pgs)	0		
WP 0014 (2 pgs)	0		
WP 0015 (2 pgs)	0		
WP 0016 (2 pgs)	0		
WP 0017 (4 pgs)	0		

*Zero in this column indicates an original page or work package.

A/B BLANK

HEADQUARTERS,
DEPARTMENT OF THE ARMY
WASHINGTON, D.C., 15 APRIL 2009

TECHNICAL MANUAL

**OPERATOR AND FIELD LEVEL
MAINTENANCE MANUAL INCLUDING REPAIR PARTS AND
SPECIAL TOOLS LIST (RPSTL)**

FOR

**3K & 5K SEMI-TRAILER MOUNTED FABRIC TANK (SMFT)
WATER, COLLAPSIBLE
MODELS**

**GTA-3K-SMFT
(NSN 5430-01-564-7919)**

**GTA-5K-SMFT
(NSN 5430-01-564-7916)**

REPORTING ERRORS AND RECOMMENDING IMPROVEMENTS

You can help improve this publication. If you find any errors, or if you would like to recommend any improvements the procedures in this publication, please let us know. The preferred method is to submit your DA Form 2028 (Recommended Changes to Publications and Blank Forms) through the Internet, on the Army Electronic Product Support (AEPS) website. The Internet address is <https://aeeps.ria.army.mil>. The DA Form 2028 is located under the Public Applications section in the AEPS Public Home Page. Fill out the form and click on SUBMIT. Using this form on the AEPS will enable us to respond quicker to your comments and better manage the DA Form 2028 program. You may also mail, email, or fax your comments or DA Form 2028 directly to U.S. Army TACOM Life Cycle Management Command, ATTN: AMSTA-LC-LMPP/TECH PUBS, 1 Rock Island Arsenal, Rock Island, IL 61299-7630. The email address is tacomlcmmc.daform2028@us.army.mil. The fax number is DSN 793-0726 or Commercial (309) 782-0726.

DISTRIBUTION STATEMENT A: Approved for public release: distribution is unlimited.

TABLE OF CONTENTS

	Page No.
	<u>WP Sequence No.</u>
WARNING SUMMARY	a
LIST OF EFFECTIVE PAGES	A
HOW TO USE THIS MANUAL.....	iii
Chapter 1. GENERAL INFORMATION, EQUIPMENT DESCRIPTION AND THEORY OF OPERATION	
General Information	WP 0001-1
Maintenance Forms, Records and Reports	WP 0001-1
Reporting Equipment Improvement Recommendations (EIR).....	WP 0001-1
Corrosion Prevention and Control (CPC).....	WP 0001-1
Destruction of Army Materiel To Prevent Enemy Use	WP 0001-2
Preparation For Storage Or Shipment	WP 0001-2
List of Abbreviations/Acronyms.....	WP 0001-2
Equipment Characteristics, Capabilities and Features	WP 0002-1
Location and Description of Major Components.....	WP 0002-1
Figure 1. Location of Component.....	WP 0002-1
Equipment Used With the Tank	WP 0002-2
Differences Between Models	WP 0002-2
Equipment Data	WP 0002-3
Information Data Plates.....	WP 0002-3
Figure 2. Tank Markings	WP 0002-4
Table 1. Tank Markings	WP 0002-4
Theory of Operation	WP 0003-1
Chapter 2. OPERATOR INSTRUCTIONS	
Description and Use of Operator Controls and Indicators	WP 0004-1
Figure 1. SMFT Controls and Indicators.....	WP 0004-1
Table 1. Description of Controls and Indicators.....	WP 0004-1
Operation Under Usual Conditions	WP 0005-1
Figure 1. Filler/Discharge Gate Valve and Hose	WP 0005-1
Figure 2. Purging Air and Tightening Tie Down Straps	WP 0005-2
Figure 3. Removing Pressure Gauge	WP 0005-3
Figure 4. Draining Tank	WP 0005-4
Operation Under Unusual Conditions	WP 0006-1
Chapter 3. TROUBLESHOOTING	
Operator Troubleshooting	WP 0007-1
Field Troubleshooting.....	WP 0008-1
Chapter 4. OPERATOR MAINTENANCE	
PMCS Procedures Instruction.....	WP 0009-1
PMCS Procedures	WP 0010-1
Table 1. Operator's Preventive Maintenance Checks and Services	WP 0010-1
Emergency Repair of Tank	WP 0011-1
Figure 1. Wood Plug Installation.....	WP 0011-1
Figure 2. Mechanical Patch Installation	WP 0011-2
Chapter 5. FIELD MAINTENANCE INSTRUCTIONS	
Service Upon Receipt	WP 0012-1
Figure 1. SMFT Crate	WP 0012-1
Figure 2. SMFT Crate Open	WP 0012-2
Figure 3. SMFT Accessories.....	WP 0012-2
Figure 4. Positioning Tie Down Straps.....	WP 0012-3
Figure 5. Typical Tie Down Positions.....	WP 0012-4
Figure 6. Lifting Tank	WP 0012-5
Figure 7. Positioning Tank on Trailer	WP 0012-6
Figure 8. Feeding Tie Down Strap Into Winch.....	WP 0012-7
Figure 9. Filler/Discharge Assembly	WP 0012-8

Figure 10. Bleeding Relief Valve.....	WP 0012-9
Figure 11 Removing Pressure Gauge	WP 0012-11
Figure 12. Draining Tank	WP 0012-13
Figure 13. Removing Inspection Plate and Pressure Gauge	WP 0012-14
Figure 14. Removing Tie Downs, Winches and Rolling Tank	WP 0012-15
Figure 15. Stowed Tank on Trailer Bed	WP 0012-16
Filler/Discharge Assembly.....	WP 0013-1
Figure 1. Disassembly of Filler/Discharge Assembly.....	WP 0013-1
Figure 2. Assembly of Filler/Discharge Assembly	WP 0013-4
Inspection Plate.....	WP 0014-1
Figure 1. Inspection Plate	WP 0014-1
Valve Cap and Core.....	WP 0015-1
Figure 1. Valve Cap and Core	WP 0015-1
Hose Assembly	WP 0016-1
Figure 1. Hose Assembly.....	WP 0016-1
Nozzle Assembly.....	WP 0017-1
Figure 1. Nozzle Assembly	WP 0017-1
Chapter 6. PARTS INFORMATION	
Repair Parts and Special Tools List (RPSTL) Introduction.....	WP 0018-1
Table 1. SMR Code Explanation.....	WP 0018-2
Tank Fabric, Collapsible.....	WP 0019-1
Figure 1. Tank Fabric, Collapsible	WP 0019-2
Tank Envelope	WP 0020-1
Figure 2. Tank Envelope.....	WP 0020-2
Filler/Discharge Assembly.....	WP 0021-1
Figure 3. Filler/Discharge Assembly	WP 0021-2
Inspection Plate.....	WP 0022-1
Figure 4. Inspection Plate	WP 0022-2
Relief Valve	WP 0023-1
Figure 5. Relief Valve.....	WP 0023-2
Hose Assembly, Four Inch.....	WP 0024-1
Figure 6. Hose Assembly, Four Inch.....	WP 0024-2
Hose Assembly, Two Inch	WP 0025-1
Figure 7. Hose Assembly, Two Inch	WP 0025-2
Nozzle Assembly.....	WP 0026-1
Figure 8. Nozzle Assembly	WP 0026-2
National Stock Number Index	WP 0027-1
Part Number Index.....	WP 0028-1
Chapter 7. SUPPORTING INFORMATION	
References.....	WP 0029-1
Maintenance Allocation Chart (MAC) Introduction.....	WP 0030-1
Maintenance Allocation Chart (MAC).....	WP 0031-1
Table 1. MAC for 3K & 5K SMFT, Water	WP 0031-1
Table 2. Tools and Test Equipment For SMFT, Water.....	WP 0031-2
Table 3. Remarks for SMFT, Water	WP 0031-3
Components of End Item (COEI) and Basic Issue Items (BII) Lists	WP 0032-1
Table 1. Components of End Item List.....	WP 0032-2
Table 2. Basic Issue Items List	WP 0032-3
Expendable and Durable Items List.....	WP 0033-1
Table 1. Expendable and Durable Items List.....	WP 0033-1
Mandatory Replacement Parts List.....	WP 0034-1
Table 1.	WP 0034-1
Alphabetical Index.....	INDEX-1

HOW TO USE THIS TECHNICAL MANUAL (TM)

This technical manual (tm) contains general information, operating and maintenance procedures for the Semi-Trailer Mounted Fabric Tank (SMFT), Water.

Front matter consists of a warning summary, table of contents, and instructions on how to use this manual. The rear matter consists of the DA Form 2028s, the authentication page and back cover.

Technical Manual Organization

This Technical Manual is divided into seven chapters that detail the topics mentioned above. Within each chapter, there are work packages covering a range of topics. Each chapter is numbered sequentially starting at Chapter 1, Work Package 0001 with work packages numbered sequentially throughout the entire TM.

Finding Information

The Table of Contents and Index permit the reader to quickly find the information they are seeking.

CHAPTER 1

**GENERAL INFORMATION, EQUIPMENT
DESCRIPTION AND THEORY OF OPERATION
FOR
3K & 5K SEMI-TRAILER MOUNTED FABRIC TANK (SMFT), WATER**

**OPERATOR AND FIELD MAINTENANCE
3K & 5K SEMI-TRAILER MOUNTED FABRIC TANK (SMFT), WATER
GENERAL INFORMATION**

SCOPE

This technical manual contains instructions for operations, checks and corrective maintenance procedures for the 3,000 and 5,000 Gallon Semi-Trailer Mounted Fabric Tanks (SMFT), Water.

Type of Manual: Operator and Field Level Maintenance.

Equipment Names and Part Numbers: 3K Semi-Trailer Mounted Fabric Tank (SMFT), Water, P/N GTA-3K-SMFT and 5K Semi-Trailer Mounted Fabric Tank (SMFT), Water, P/N GTA-5K-SMFT.

Purpose of Equipment: The 3K SMFT, transported on M871 and M872 series semi-trailers, and 5K SMFT, transported on M872 series semi-trailers, are used to store and dispense potable drinking water.

MAINTENANCE FORMS, RECORDS, AND REPORTS

Department of the Army forms and procedures used for equipment maintenance will be those prescribed by (as applicable) DA PAM 750-8, The Army Maintenance Management System (TAMMS) Users Manual; DA PAM 738-751, Functional Users Manual for The Army Maintenance Management System-Aviation (TAMMS-A); or AR 700-138, Army Logistics Readiness and Sustainability.

REPORTING EQUIPMENT IMPROVEMENT RECOMMENDATIONS (EIR)

If your SMFT needs improvement, let us know. Send us an EIR. You, the user, are the only one who can tell us what you don't like about your equipment. Let us know why you don't like the design or performance. (E-Mail: TACOM-TECH-PUBS@conus.army.mil) We will send you a reply. The preferred method for submitting Quality Deficiency Reports (QDRs) is through the Army Electronic Product Support (AEPS) website under the Electronic Deficiency Reporting System (EDRS). The web address is: <https://aeprs.ria.army.mil>. If the above method is not available to you, put it on an SF 368 (Product Quality Deficiency Report) and mail it to us at: Department of the Army, U.S. Army Tank-automotive and Armaments Command, AMSRD-TAR-E, PDQR MS 268, 6501 E. 11 Mile Road, Warren, MI 38397-5000.

CORROSION PREVENTION AND CONTROL (CPC)

Corrosion Prevention and Control (CPC) of Army materiel is a continuing concern. It is important that any corrosion problems with this item be reported so that the problem can be corrected and improvements can be made to prevent the problem in future items. Corrosion specifically occurs with metals. It is an electrochemical process that causes the degradation of metals. It is commonly caused by exposure to moisture, acids, bases, or salts. An example is the rusting of iron. Corrosion damage in metals can be seen, depending on the metal, as tarnishing, pitting, fogging, surface residue, and/or cracking. Plastics, composites, and rubbers can also degrade. Degradation is caused by thermal (heat), oxidation (oxygen), solvation (solvents), or photolytic (light, typically UV) processes. The most common exposures are excessive heat or light. Damage from these processes will appear as cracking, softening, swelling, and/or breaking. SF Form 368, Product Quality Deficiency Report should be submitted to the address specified in DA PAM 750-8, The Army Maintenance Management System (TAMMS) Users Manual.

DESTRUCTION OF ARMY MATERIEL TO PREVENT ENEMY USE

Refer to TM 750-244-3 for information and instructions covering destruction of Army Materiel.

PREPARATION FOR STORAGE OR SHIPMENT

Refer to Work Package 0012.

LIST OF ABBREVIATIONS/ACRONYMS

C	centigrade
cm	centimeter(s)
F	fahrenheit
ft	foot/feet
gal	gallon
in.	inch
kg	kilogram
km	kilometer
kPa	kilopascal
lbs	pounds
m	meter(s)
MPH	miles per hour
NBC	Nuclear, Biological and Chemical
N*m	newton meter
P/N	part number
psi	pounds per square inch
SMFT	semi-trailer mounted fabric tank
WP	work package

**OPERATOR AND FIELD MAINTENANCE
3K & 5K SEMI-TRAILER MOUNTED FABRIC TANK (SMFT), WATER
EQUIPMENT CHARACTERISTICS, CAPABILITIES AND FEATURES**

EQUIPMENT CHARACTERISTICS, CAPABILITIES AND FEATURES

The SMFT is a collapsible fabric tank used to transport, store and dispense drinking water into areas where normal water access is not available. The tanks are constructed of elastomeric coated multi-ply fabric or multi-ply cord. The tanks are transported on semi-trailers when completely full or collapsed and rolled. When not in use, the tank may be rolled and stored.

LOCATION AND DESCRIPTION OF MAJOR COMPONENTS

Locations of major components are shown on Figure 1.

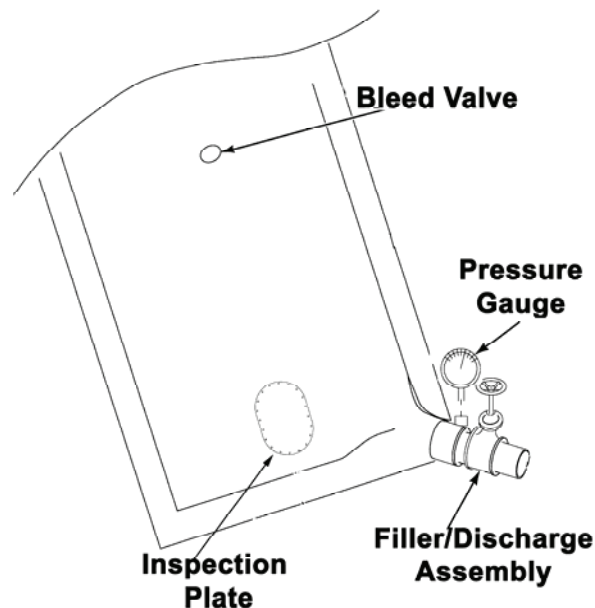

Figure 1. Location of Components.

Filler/Discharge Assembly

The filler/discharge assembly is located at the forward, right side of the tank. It consists of a 4-inch gate valve and a flanged casting, with a shutoff valve and pressure gauge clamped inside the tank. The open end has a 4-inch male quick-disconnect coupling half, for connecting suction hose, and a chained dust cap.

Pressure Gauge

A low pressure gauge, mounted on the filler/discharge assembly, monitors tank pressure during filling and use. It is a sensitive and accurate gauge that monitors pressures between 0-10 psi, with a nominal reading between 4-6 psi. It is installed with an adapter (ball valve) that allows pressure to the gauge to be shut off when not in use.

Inspection Plate

An inspection plate is located on the forward, top center end of the tank. It provides access to enter and clean or dry the inside of the tank.

Bleed Valve

A bleed valve is located on the top center of the tank, which is used to release air pressure during filling.

EQUIPMENT USED WITH THE TANK**Tie-Down Assembly**

The tie-down assembly consists of 4-inch wide straps with sleeves and a winch that mounts in trailer stake pockets. Using the take up mechanism and applying tension to the straps, the winch hook is secured to the bottom of the stake pocket and minimizes tank movement during transport.

Protective Flatbed Cloth with Lifting Handles

The cloth provides a protective barrier between the tank and the semi-trailer flat bed during transportation. When rolled with tank, it provides four lifting handles to be used with a mechanical lift for moving the tank.

Hoses, 3K SMFT

Two 10 foot, 2-inch diameter hose assemblies, with a male cam-lock coupling and chained dust cap on one end and a female cam-lock coupling with a chained dust plug other end.

Two 10 foot, 4-inch diameter hose assemblies, with a male cam-lock coupling and chained dust cap on one end and a female cam-lock coupling with a chained dust plug other end.

Quick Reducer

One 4-inch female to a 2-inch male cam-lock reducer.

Nozzle Assembly

A nozzle assembly consists of a 2-inch quick-disconnect coupling half with a dust plug, a pipe swing joint and a nozzle. When assembled, the nozzle has a 360° rotation.

Hoses, 5K SMFT

Two 10 foot, 4-inch diameter hose assemblies, with a male cam-lock coupling and chained dust cap on one end and a female cam-lock coupling with a chained dust plug other end.

Repair Kit

The repair kit, stowed in a manually sealed container, includes plugs for temporary repairs and repair clamps for making repairs up to 6 inches. The repair kit container is marked:

REPAIR KIT
TYPE II
COLLAPSIBLE
FABRIC TANKS

DIFFERENCES BETWEEN MODELS

The 3K SMFT holds 3,000 gallons of water and the 5K SMFT holds 4,600 gallons of water and is larger in size.

EQUIPMENT DATA

OPERATING TEMPERATURE (AMBIENT)

LOW..... 32°F (0°C)
 HIGH..... 125°F (52°C)

STORAGE TEMPERATURE (AMBIENT)

LOW..... -25°F (-31.70°C)
 HIGH..... 160°F (71.1°C)

SPECIFICATIONS, 3K SMFT, P/N: GTA-3K-SMFT

MANUFACTURER..... GTA Container, Inc. South Bend, Indiana
 NSN 5430-01-564-7919
 NOMINAL DRY DIMENSIONS (UNROLLED)..... 26 ft. l x 7 ft 2 in. w x 2 in. h (7.9m x 2.18m x 5.1cm)
 WEIGHT (EMPTY)..... 396 lbs (180kg)
 NOMINAL HEIGHT (FILLED)..... 54 in. (137cm)
 NOMINAL WIDTH (FILLED)..... 7 ft (2.1m)
 NOMINAL LENGTH (FILLED)..... 26 ft. (7.9m)
 CAPACITY..... 3,000 gal (11,355L)

SPECIFICATIONS, 5K SMFT, P/N: GTA-5K-SMFT

MANUFACTURER..... GTA Container, Inc. South Bend, Indiana
 NSN 5430-01-564-7916
 NOMINAL DRY DIMENSIONS (UNROLLED)... 39 ft 6 in. l x 7 ft 2 in. w x 2 in. h (12m x 2.2m x 5.1cm)
 WEIGHT (EMPTY)..... 775 lbs (51.5kg)
 NOMINAL HEIGHT (FILLED)..... 54 in. (137cm)
 NOMINAL WIDTH (FILLED)..... 7 ft (2.1m)
 NOMINAL LENGTH (FILLED)..... 36 ft 6 in. (11.13m)
 CAPACITY..... 4,600 gal (17,413L)

INFORMATION DATA PLATES

3K SMFT

TANK, FABRIC, COLLAPSIBLE:
 3,000 GALLONS, DRINKING WATER
 NSN: 5430-01-564-7919
 SERIAL NO: 0001
 PIN: GTA-3K-SMFT
 MFR: GTA CONTAINERS, INC. SOUTH BEND, IN
 DATE MANUFACTURED: JUN 2008
 WEIGHT EMPTY: 396
 CONTRACT OR ORDER NO: W56HZV-08-D-0139-0001
 LOT: 01
 SERVICE LIFE 5 YEARS
 STORAGE LIFE 20 YEARS

5K SMFT

TANK, FABRIC, COLLAPSIBLE:
 4,600 GALLONS, DRINKING WATER
 NSN: 5430-01-564-7916
 SERIAL NO: 0001
 PIN: GTA-5K-SMFT
 MFR: GTA CONTAINERS, INC. SOUTH BEND, IN
 DATE MANUFACTURED: JUN 2008
 WEIGHT EMPTY: 775
 CONTRACT OR ORDER NO: W56HZV-08-D-0139-0001
 LOT: 01
 SERVICE LIFE 5 YEARS
 STORAGE LIFE 20 YEARS

The tank marking locations are shown on Figure 2 and the markings are listed in Table 1.

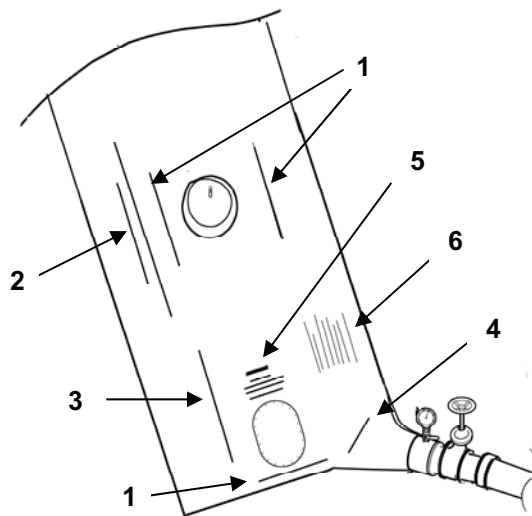

Figure 2. Tank Markings.

Table 1. Tank Markings

Key	Tank Markings
1	DRINKING WATER
2	TRANSPORT TANK ONLY WHEN COMPLETELY FULL OR EMPTY REMOVE GAUGE WHEN TRANSPORTING
3	PLACE TIEDOWN STRAP HERE
4	FILL TANK TO 5 PSIG
5	WARNING DANGER PERMIT REQUIRED CONFINED SPACE DO NOT ENTER
6	Information Data Plate

**OPERATOR AND FIELD MAINTENANCE
3K & 5K SEMI-TRAILER MOUNTED FABRIC TANK (SMFT), WATER
THEORY OF OPERATION**

Principles of Operation

The SMFT is used to store, transport or disperse potable (drinking) water. The tanks are transported on M871 or M872 series semi-trailers, only when completely full and secured with tie down straps wrapped around the tank in four or five places or, when empty, rolled and secure to the trailer.

The tie down straps, four for the 3 K and five for the 5 K SMFT, are placed across the trailer at trailer stake pockets with even amounts hanging over each side. The tank with ground cloth is placed on the rear of the trailer and unrolled toward the front of the trailer. The free ends of the tie down straps are placed over the top of the tank and down the other side. The winches are placed on each side of the trailer in the stake pockets at the tie down location. The free end of the tie down strap is placed through the winch take-up mechanism about one foot and manually taken up on the roll-up spool.

The tank and water source supply hose are purged of air then connected to the filler/discharge valve. The water source valve is opened and the tank filler/discharge gate valve is opened allowing water to enter the tank. The pressure gauge will not indicate a pressure until the tank reaches approximately 2 feet in height. The pressure gauge should then be monitored periodically by shutting off the filler/discharge gate valve, take a pressure reading and continue filling until reaching 2 – 2.5 psi (14 - 17 kPa). The relief valve, on top of the tank, is opened until water flows from the valve. The tie down straps are then tightened uniformly, keeping the tank level, until the straps are firm and tight. Continue filling the tank until pressure gauge reads between 4 - 6 psi (21- 41 kPa). The tank is full and ready for transporting.

Full tanks can be transported on a grade and slide slope of 30 percent, and up to 55 MPH (80 km) over highways or 30 MPH (48 km) over unimproved roads, open, rolling and hilly cross country terrain. There should be no shifting, leaking or any deterioration to the tank surface.

The tanks can be gravity drained by raising the front of the semi-trailer 8 – 10 inches (20 – 25 cm) higher than the filler/discharge valve. A 2 inch suction hose with reducer, or 4 inch suction hose is connected to the filler/discharge gate valve to allow draining. The use of air pressure to unload the tank is prohibited, as it may cause the tank to burst causing injury to personnel. After opening the filler/discharge gate valve, the tank will completely drain in 30 minutes or less.

The internal inspection and cleaning of the tank is performed by removing the inspection plate on top of the tank. Wearing soft soled shoes, a person must stand in the access opening; lift the tank around them while high volume low pressure air is supplied into the tank. Once the tank is inflated, inspection and cleaning can be accomplished. This task must be performed to completely dry the inside of the tank before storing for a period of time.

CHAPTER 2

OPERATOR INSTRUCTIONS
FOR
3K & 5K SEMI-TRAILER MOUNTED FABRIC TANK (SMFT), WATER

**OPERATOR
3K & 5K SEMI-TRAILER MOUNTED FABRIC TANK (SMFT), WATER
DESCRIPTION AND USE OF OPERATOR CONTROLS AND INDICATORS**

GENERAL

This section lists system controls and indicators and describes the functions within the SMFT.

DESCRIPTION AND USE OF CONTROLS AND INDICATORS

Descriptions and use of major components, including controls and indicators are illustrated in Figure 1 and described in Table 1.

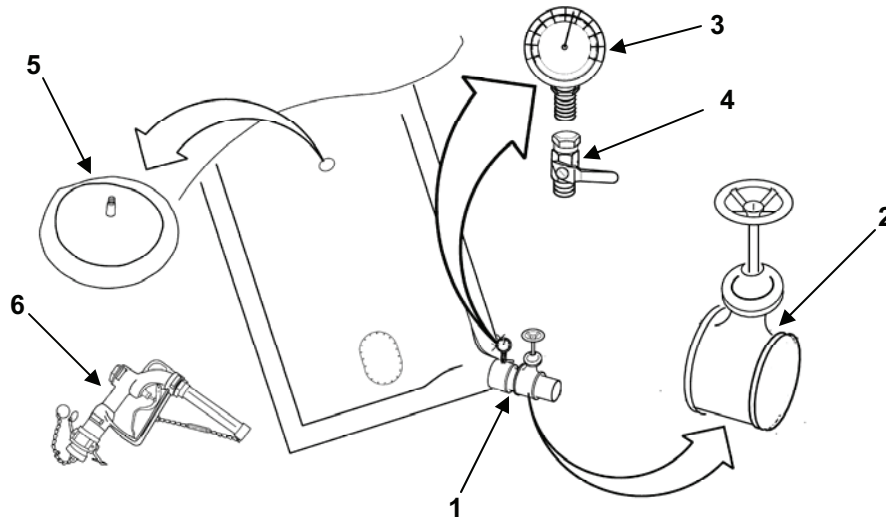

Figure 1. SMFT Controls and Indicators

Table 1. Description of Controls and Indicators.

Key	Control or Indicator	Function
1	Filler/discharge assembly	The filler/discharge assembly consists of a 4-inch gate valve, pressure gauge and 4 inch flange casting with seal. It provides the connection necessary to fill and empty the tank.
2	Gate Valve, 4 inch	Controls the flow of water out of the tank.
3	Pressure gauge	A 0-10 psi pressure gage is supplied to monitor the pressure during filling and of the tank during use. Operating pressure is 4 - 6 psi.

Table 1. Description of Controls and Indicators (cont.).

Key	Control or Indicator	Function
4	Adapter shut off valve	Used to control air pressure reading to the pressure gauge.
5	Pressure Relief Valve	Located on top of tank, the valve core can be manually opened with finger pressure to relieve trapped air or using pneumatic tire valve repair tool.
6	Nozzle Assembly	Controls the flow of water from a two inch hose on the 3K SMFT.

**OPERATOR
3K & 5K SEMI-TRAILER MOUNTED FABRIC TANK (SMFT), WATER
OPERATION UNDER USUAL CONDITIONS**

INITIAL SETUP:

Reference:
WP 0012

FILLING THE TANK**WARNING**

Trailer must be on level ground for filling to prevent tank from rolling off trailer before it is secured and causing injury to personnel.

NOTE

Contact Field Maintenance for assistance in performing this task.

1. Open adapter shutoff valve (Figure 1, Item 1).

NOTE

Before using tank for the first time or after prolonged storage, flush tank with solution of 0.5 gallons of bleach mixed in 250 gallons of fresh water. Surge cleaning solution by walking back and forth on tank. Rinse tank with 250 gallons of clean water to remove bleach taste. When cleaning is complete, close tank valve immediately to hermetically seal out contaminants.

2. Remove quick disconnect cap (Figure 1, Item 2) from filler/discharge gate valve (Figure 1, Item 3).
3. Open filler/discharge gate valve (Figure 1, Item 3) and ensure all air has been expelled from tank, then close gate valve.
4. Remove plug (Figure 1, Item 4) and quick disconnect cap (Figure 1, Item 5) from 4 inch suction hose (Figure 1, Item 6).
5. Attach suction hose (Figure 1, Item 6) to water source, open water source valve and purge hose of air.
6. Once water is discharged from hose, shut off water source valve.
7. Attach suction hose (Figure 1, Item 6) to quick disconnect coupling half (Figure 1, Item 7) and lock into position.
8. Open water source valve.
9. Open filler/discharge gate valve (Figure 1, Item 3).

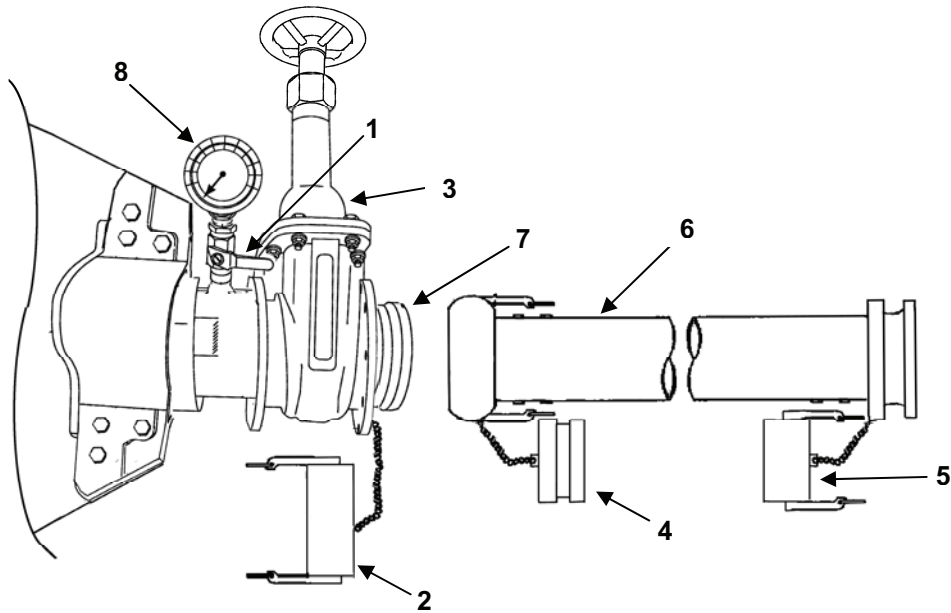

Figure 1. Filler/Discharge Gate Valve and Hose.

NOTE

Shut off gate valve each time a pressure reading is taken.

10. Fill tank until approximately two to three feet high and begin monitoring pressure gauge (Figure 1, Item 8), by shutting off filler/discharge gate valve (Figure 1, Item 3) and take a pressure reading.
11. Continue filling tank and take pressure readings until pressure gauge (Figure 1, Item 8) reads between 2 – 2.5 psi (14 – 17 kPa), then shut off filler/discharge gate valve (Figure 1, Item 3).
12. Remove dust cap (Figure 2, Item 1) from relief valve on top of tank and depress valve stem until water flows from valve.
13. Replace dust cap (Figure 2, Item 1).

NOTE

Tie down straps must be tightened uniformly to ensure there is no movement of tank once filled. Should tank not appear uniform, tie down straps must be loosened and retightened accordingly.

14. Using winch bar (Figure 2, Item 2), uniformly tighten all tie down straps (Figure 2, Item 3), ensuring straps wind true and flat, until tie down straps are taut. Tank pressure will increase slightly.

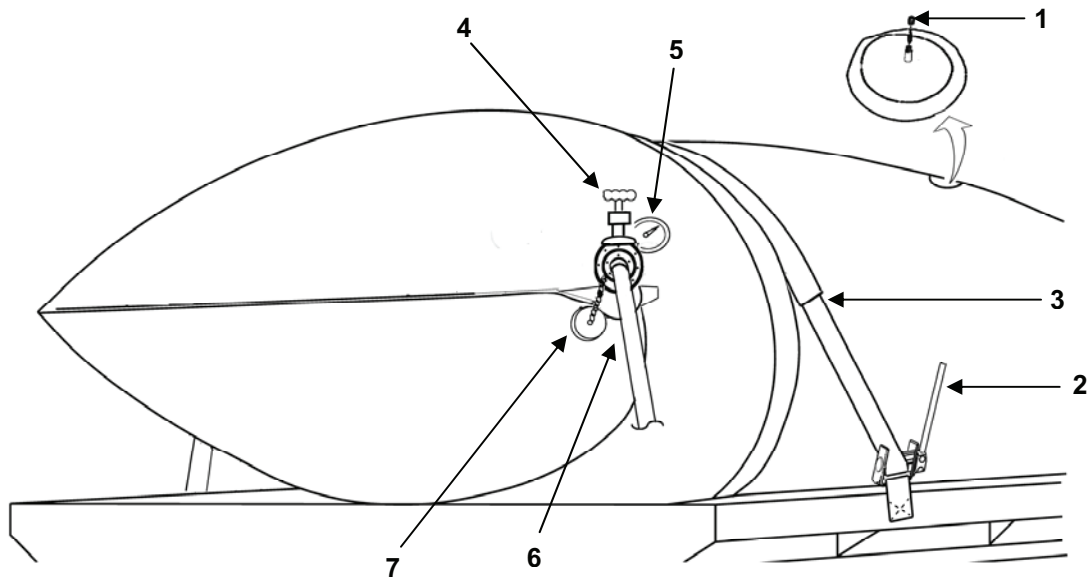

Figure 2. Purging Air and Tightening Tie Down Straps.

CAUTION

Slowly open filler/discharge valve when beginning to fill tank, to avoid high pressure water being applied and damaging tank.

NOTE

Shutting off water source valve first, then filler/discharge assembly gate valve, will create a low pressure in the suction hose.

15. Slowly open filler/discharge gate valve (Figure 2, Item 4) and continue filling tank until pressure gauge (Figure 2, Item 5) reads between 4 – 6 psi (21 -41 kPa), then shut off water source valve.
16. Shut off filler/discharge gate valve (Figure 2, Item 4).
17. Remove hose (Figure 2, Item 6) from water source and filler/discharge gate valve (Figure 2, Item 4).
18. Install quick disconnect cap (Figure 2, Item 7) on filler/discharge gate valve with locking arms in horizontal position.

NOTE

If tank is not moved for any period of time, it is normal for pressure to drop 1-2 psi as tank fabric relaxes, this may become more evident at higher temperatures.

After tank has been filled and emptied for the first time, the filler/discharge clamp cap screws must be checked for proper torque.

PREPARATION FOR MOVEMENT**WARNING**

Tank must be transported only when completely full or completely empty to prevent injury to personnel.

Full Tank

1. When tank is full, prior to movement, ensure tie down straps are secure and tight.

CAUTION

Quick disconnect cap locking handles must be placed in horizontal position to prevent damage to cap during emergency stops.

2. Ensure filler/discharge (Figure 2, Item 4) quick disconnect cap (Figure 2, Item 7) handles in horizontal position.
3. Obtain pipe plug (Figure 3, Item 1).
4. Remove pressure gauge (Figure 3, Item 2) and install pipe plug (Figure 3, Item 1).

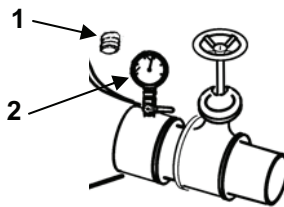

Figure 3. Removing Pressure Gauge.

5. Ensure all components have been properly stowed and secured.

WARNING

Should an emergency stop or dramatic maneuver be made during transportation, stop and check tank position, tie down straps position and tension to prevent injury to personnel should tank become loose.

6. After first 2 to 5 miles of travel, stop and check tie downs for security and that tank has not shifted.

7. Repeat steps 5 and 6 after 10 to 15 miles (16 – 24 km) of travel and after 30 to 35 (48 – 56 km) miles of travel.
8. If no change is noted, no further inspection is required.

Empty Tank

1. When tank is empty, prior to movement, tank must be rolled and securely latched to trailer.
2. Ensure all components have been properly stowed and secured.

DRAINING TANK

WARNING

The tank can only be emptied by gravity or suction pump. Use of air pressure to unload tank is not authorized as it may cause the tank to burst under pressure and cause injury to personnel.

Gravity Draining

1. Raise forward end and left side of trailer bed 8 - 10 inches higher than filler/discharge gate valve (Figure 4, Item 1) end.
2. Connect 4 inch suction hose (Figure 4, Item 2) to quick disconnect coupling half (Figure 4, Item 3) and position hose to discharge area.
3. Close adapter shutoff valve (Figure 4, Item 4).
4. Open filler/discharge gate valve (Figure 4, Item 1) to start flow.

NOTE

When completely full, tank will drain in less than 30 minutes.

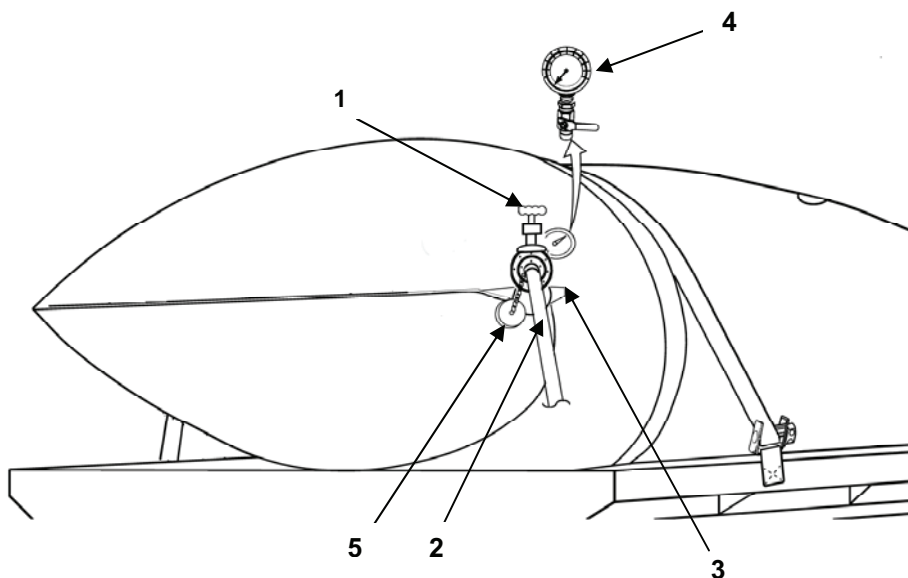

Figure 4 Draining Tank.

5. After tank has drained completely, close filler/discharge gate valve (Figure 4, Item 1).
6. Disconnect suction hose (Figure 4, Item 2) from quick disconnect coupling half (Figure 4, Item 3).
7. Install quick disconnect cap (Figure 4, Item 5) with locking arms in horizontal position.

Pump Draining

1. Raise forward end and left side of trailer bed 8 – 10 inches higher than filler/discharge gate valve (Figure 4, Item 1) end.
2. Connect 4 inch suction hose (Figure 4, Item 2) to quick disconnect coupling half (Figure 4, Item 3) and position hose to discharge area
3. Connect opposite end of suction hose (Figure 4, Item 2) to pump.
4. Close adapter shutoff valve (Figure 4, Item 4).
5. Open filler/discharge gate valve (Figure 4, Item 1).
6. Start pump and open filler/discharge gate valve (Figure 4, Item 1) to begin draining.
7. After tank has drained completely, close filler/discharge gate valve (Figure 4, Item 1).
8. Close pump valve.
9. Disconnect suction hose (Figure 4, Item 2).
10. Install quick disconnect cap (Figure 4, Item 5) with locking arms in horizontal position.
11. Disconnect suction hose from pump.

END OF WORK PACKAGE

OPERATOR
3K & 5K SEMI-TRAILER MOUNTED FABRIC TANK (SMFT), WATER
OPERATION UNDER UNUSUAL CONDITIONS

INITIAL SETUP:**Materials/Parts:**

- Brush, Scrub (WP 0033, Item 2)
- Detergent, General Purpose (WP 0033, Item 4)

OPERATION IN EXTREME HEAT

When operating in extreme heat the following precautions should be observed:

1. Tank should be set up in shaded area, covering or constructing a sun block.
2. Tank should be well ventilated, allowing air flow around tank.
3. Avoid unnecessary folding and unfolding of empty tank.

OPERATION IN EXTREME COLD**CAUTION**

Operating in temperatures below 32°F (0°C), caution must be taken to prevent tank water and filler/discharge assembly from freezing. Damage to tank and fitting may occur, if water freezes.

Tank must be handled with care to prevent cracking or damage to tank skin.

1. Do not allow snow and/or ice to form on relief valve assembly.
2. Do not allow snow and/or ice to form on filler/discharge assembly.
3. Do not allow heavy snow or ice to form on tank.

OPERATION IN SALT WATER AREAS

Clean the filler/discharge assembly with clean water prior to filling or drawing water from the tank.

OPERATION IN SANDY OR DUSTY AREAS

1. Cover filler/discharge assembly when not in use.
2. Keep plugs and caps on filler/discharge assembly and hoses when not in use.

OPERATION IN MUD

1. Ensure filler/discharge is clean before filling or drawing water from the tank.
2. Keep hoses up and out of mud.
3. Keep plugs and caps on hoses when not in use.

OPERATION IN HIGH WIND

1. Keep tank as full of water as possible.
2. Keep tie down straps tight around tank

OPERATION IN RAIN

Provide adequate drainage ditches around tank to prevent standing pools of water.

INTERIM NUCLEAR, BIOLOGICAL, AND CHEMICAL (NBC) DECONTAMINATION PROCEDURES**NOTE**

Detailed decontamination procedures can be found in FM 3-3, FM 3-4, and FM 3-5.

General

The following emergency procedures can be performed until field NBC decontamination facilities are available.

Emergency Procedures**WARNING**

If NBC attack is known or suspected, mask at once and continue mission. Do not remove your mask until told to do so. Removing mask could cause injury or death.

1. Nuclear decontamination - Brush fallout from skin, clothing, and equipment with available brushes, rags and tree branches. Wash skin and have radiation check made as soon as tactical situation permits.
2. Biological decontamination - Remain masked and continue mission until told to unmask.
3. Chemical detection and decontamination.

WARNING

Do not use decontamination spray on personnel. It could cause personal injury.

- a. Use M8 paper from M256 chemical agent detector kit or M9 paper to determine if liquid agent is present on surface of equipment.
- b. If exposure to liquid agent is known or suspected, clean exposed skin, clothing and personal gear, in that order, using M258A1 kit. Use buddy system. Wash exposed skin and thoroughly decontaminate as soon as tactical situation permits.
- c. If M8 or M9 paper indicates liquid chemical agent is present, rinse exposed portion of collapsible tank with a liberal amount of water. When tactical situation permits, wash collapsible tank with soapy water and rinse thoroughly.
- d. Decontamination procedures take time. Do as much as you can, depending on tactical situation.

END OF WORK PACKAGE

CHAPTER 3

TROUBLESHOOTING PROCEDURES
FOR
3K & 5K SEMI-TRAILER MOUNTED FABRIC TANK (SMFT), WATER

**OPERATOR
3K & 5K SEMI-TRAILER MOUNTED FABRIC TANK (SMFT), WATER
OPERATOR TROUBLESHOOTING PROCEDURES**

INITIAL SETUP:**Tools:**

Repair Kit (WP 0031, Item 3)

INTRODUCTION TO OPERATOR TROUBLESHOOTING

Troubleshooting Procedures list common malfunctions that you may find during operation or maintenance of the SMFT or its components. Perform tests/inspections and corrective actions in the order listed in the procedures.

This manual cannot list all malfunctions that may occur nor all tests or inspections and corrective actions. If a malfunction is not listed or is not corrected by listed corrective actions, notify your supervisor.

TROUBLESHOOTING PROCEDURE**TANK****SYMPTOM**

Tank leaks.

MALFUNCTION

Check tank for cuts, tears, or punctures.

CORRECTIVE ACTION

Perform emergency repairs using wood plugs (WP 0011).
If leak cannot be repaired, notify field maintenance.

TROUBLESHOOTING PROCEDURE**FILLER/DISCHARGE ASSEMBLY****SYMPTOM**

Filler/Discharge leaks at clamp area.

MALFUNCTION

Check for loose or missing bolts on clamps.

CORRECTIVE ACTION

If bolts are loose or missing, notify field maintenance.

MALFUNCTION

Check clamps for cracks.

CORRECTIVE ACTION

If clamps are cracked, notify field maintenance.

TROUBLESHOOTING PROCEDURE

FILLER/DISCHARGE ASSEMBLY

SYMPTOM

Gate valve leaks at flanged areas.

MALFUNCTION

Check for loose or missing bolts and nuts on flange.

CORRECTIVE ACTION

If bolts or nuts are loose or missing, notify field maintenance.

TROUBLESHOOTING PROCEDURE

COUPLING HALF QUICK DISCONNECT

SYMPTOM

Coupling half leaks at output area.

MALFUNCTION

Check for gouges, nicks or cuts on cam lock area.

CORRECTIVE ACTION

If damage is found, notify field maintenance.

TROUBLESHOOTING PROCEDURE

PRESSURE GAUGE

SYMPTOM

Pressure gauge does not indicate pressure.

MALFUNCTION

Check for damage to pressure gauge.

CORRECTIVE ACTION

If pressure gauge is damaged, notify field maintenance.

MALFUNCTION

Check if adapter valve is open.

CORRECTIVE ACTION

If open and no reading, notify field maintenance

TROUBLESHOOTING PROCEDURE

PRESSURE RELIEF VALVE

SYMPTOM

Pressure relief valve leaks.

MALFUNCTION

Check for loose valve core.

CORRECTIVE ACTION

If loose, notify field maintenance.

TROUBLESHOOTING PROCEDURE

INSPECTION PLATE

SYMPTOM

Inspection plate leaks.

MALFUNCTION

Check for loose or missing bolts.

CORRECTIVE ACTION

If bolts are loose or missing, notify field maintenance.

TROUBLESHOOTING PROCEDURE

NOZZLE ASSEMBLY

SYMPTOM

Nozzle leaks or won't dispense water.

MALFUNCTION

Check nozzle is properly connected.

CORRECTIVE ACTION

Replace nozzle assembly.

TROUBLESHOOTING PROCEDURE

NOZZLE ASSEMBLY

SYMPTOM

Pipe swing joint leaks.

MALFUNCTION

Check pipe swing joint is properly connected.

CORRECTIVE ACTION

Replace pipe swing joint.

TROUBLESHOOTING PROCEDURE

NOZZLE ASSEMBLY

SYMPTOM

Coupling half quick disconnect leaks.

MALFUNCTION

Check coupling half is properly connected.

CORRECTIVE ACTION

Replace coupling half.

TROUBLESHOOTING PROCEDURE

TIE DOWN ASSEMBLY

SYMPTOM

Winch take up mechanism does not operate.

MALFUNCTION

Check for damage or broken components.

CORRECTIVE ACTION

Replace winch.

SYMPTOM

Tie down strap is badly frayed or cut.

MALFUNCTION

Tie down strap does not hold tension.

CORRECTIVE ACTION

Replace tie down straps.

END OF WORK PACKAGE

FIELD MAINTENANCE
3K & 5K SEMI-TRAILER MOUNTED FABRIC TANK (SMFT), WATER
FIELD TROUBLESHOOTING PROCEDURES

INITIAL SETUP:**Tools:**

- Repair Kit (WP 0031, Item 3)
- Torque Wrench, 0-100 ft-lbs (WP 0031, Item 4)

Materials/Parts:

- Sealing Compound (WP 0033, Item 3)
-

INTRODUCTION TO FIELD TROUBLESHOOTING

Troubleshooting Procedures list common malfunctions that you may find during operation or maintenance of the SMFT or its components. Perform tests/inspections and corrective actions in the order listed in the table.

This manual cannot list all malfunctions that may occur, nor all tests or inspections and corrective actions. If a malfunction is not listed or is not corrected by listed corrective actions, notify your supervisor.

TROUBLESHOOTING PROCEDURE**TANK****SYMPTOM**

Tank leaks.

MALFUNCTION

Check tank for cuts, tears or punctures.

CORRECTIVE ACTION

Install mechanical patch (WP 0011). If leak cannot be repaired, replace tank.

TROUBLESHOOTING PROCEDURE**FILLER/DISCHARGE ASSEMBLY****SYMPTOM**

Filler discharge leaks at clamp area.

MALFUNCTION

Check for loose or missing bolts on clamp.

CORRECTIVE ACTION

Install new and/or tighten bolts to 85.0 ± 5 ft lbs (115 ± 7 N·m).

MALFUNCTION

Check clamps for cracks.

CORRECTIVE ACTION

Replace cracked clamp (WP 0013).

MALFUNCTION

Check flange casting seal for damage.

CORRECTIVE ACTION

Replace flange casting with seal (WP 0013).

SYMPTOM

Filler/discharge leaks at top clamp, cap screw head.

MALFUNCTION

Damaged packing with retainer.

CORRECTIVE ACTION

Install new packing with retainer and tighten bolts to 85.0 ± 5 ft lbs (115 ± 7 N·m).

SYMPTOM

Filler/discharge leaks at bottom clamp, cap screw threads.

MALFUNCTION

Cap screw requires sealing compound.

CORRECTIVE ACTION

Back out cap screws to expose threads, apply sealing compound and tighten bolts to 85.0 ± 5 ft lbs (115 ± 7 N·m).

SYMPTOM

Gate valve leaks at flange casting, flanged area.

MALFUNCTION

Check for loose or missing bolts and nuts on flange.

CORRECTIVE ACTION

Install new bolt or nut if missing, and/or tighten bolts to 35 ft lbs (47 N·m) maximum.

MALFUNCTION

Bolts and nuts are tight, but leaks at flange.

CORRECTIVE ACTION

Replace flange gasket.

SYMPTOM

Gate valve leaks at coupling half quick disconnect, flanged area.

MALFUNCTION

Check for loose or missing bolts and nuts on flange.

CORRECTIVE ACTION

Install new bolt or nut if missing, and/or tighten bolts to 35 ft lbs (47 N·m) maximum.

MALFUNCTION

Bolts and nuts are tight, but leaks at flange.

CORRECTIVE ACTION

Replace flange gasket.

TROUBLESHOOTING PROCEDURE**FLANGED COUPLING HALF QUICK DISCONNECT****SYMPTOM**

Coupling half leaks at output area.

MALFUNCTION

Check for gouges, nicks or cuts on coupling half.

CORRECTIVE ACTION

Replace coupling half quick disconnect.

TROUBLESHOOTING PROCEDURE**PRESSURE GAUGE****SYMPTOM**

Pressure gauge does not indicate pressure.

MALFUNCTION

Pressure gauge damaged.

CORRECTIVE ACTION

Replace pressure gauge.

MALFUNCTION

Needle does not indicate pressure.

CORRECTIVE ACTION

Check adapter shut off valve is open. If open, close shut off valve and remove pressure gauge.

Blow in to pressure gauge. Pressure should read 1.5 to 2.5 psi. If no pressure reading, replace pressure gauge.

TROUBLESHOOTING PROCEDURE**PRESSURE RELIEF VALVE****SYMPTOM**

Relief valve leaks.

MALFUNCTION

Valve core is loose or damaged.

CORRECTIVE ACTION

Tighten or replace valve core.

TROUBLESHOOTING PROCEDURE**INSPECTION PLATE****SYMPTOM**

Inspection Plate leaks.

MALFUNCTION

Loose or missing bolts.

CORRECTIVE ACTION

Replace missing bolt and/or tighten bolts to 10 ft lbs (13.6 N·m) maximum.

MALFUNCTION

Seal is gouged, nicked or cut.

CORRECTIVE ACTION

Replace inspection plate seal.

MALFUNCTION

Plate is cracked.

CORRECTIVE ACTION

Replace inspection plate.

END OF WORK PACKAGE

CHAPTER 4
OPERATOR MAINTENANCE
FOR
3K & 5K SEMI-TRAILER MOUNTED FABRIC TANK (SMFT), WATER

**OPERATOR MAINTENANCE
3K & 5K SEMI-TRAILER MOUNTED FABRIC TANK (SMFT), WATER
PMCS PROCEDURES INTRODUCTION**

INTRODUCTION**General**

Preventive Maintenance Checks and Services (PMCS) are performed to keep the SMFT in operating condition. The checks are used to find, correct or report problems. Be sure to perform your PMCS each time you service the tank assembly. Using the PMCS table, always do PMCS in the same order, so it gets to be a habit. With practice, you will quickly detect problems. Pay attention to WARNING and CAUTION statements. A WARNING means someone could be hurt. A CAUTION means the equipment could be damaged.

Before you use the tank assembly, do "Before" PMCS.

During use, do "During" PMCS.

After the tank assembly is used, do "After" PMCS.

If you find something wrong when performing PMCS, fix it if you can, using troubleshooting procedures and/or maintenance procedures.

Use DA Form 2404 (Equipment Inspection and Maintenance Worksheet) to record any faults that you discover before, during or after operation, unless you can fix them. You do not need to record faults that you fix. For further information on how to use this form, see DA PAM 738-750.

PMCS Procedures

Table 1 lists checks and services required to keep the SMFT in operating condition. PMCS procedures are arranged in a logical sequence requiring minimum time and motion on the part of the person(s) performing them and shall be so arranged that there will be minimum interference between persons performing the checks simultaneously on the SMFT. An explanation of each column is provided below.

- a. The "Item No." column provides the sequential identification number for each task.
- b. The "Interval" column indicates when each check or service is to be performed.
- c. The "Item To Be Checked or Serviced" column tells you on which item the procedure is to be performed.
- d. The "Procedure" column tells you how to do the required checks and services. Carefully follow these instructions. If you do not have the required tools or if the procedure tells you to, notify your supervisor.
- e. The "Equipment Not Ready/Available If" column tells you the condition under which the SMFT would not be capable of performing its intended mission.

Leakage Definitions

Class I	Seepage of water (as indicated by wetness or discoloration) not great enough to form drops.
Class II	Leakage of water great enough to form drops but not enough to cause the drops to drip or run from the faulty area.
Class III	Leaks of water great enough to form drops that fall or run or collect in puddles near the faulty area.
Class IV	Leakage found under the tank. There is evidence of dampness on the ground cloth or on the ground. Volume of water in tank is less than it should be.

LUBRICATION

There is no lubrication required for the SMFT.

**OPERATOR MAINTENANCE
3K & 5K SEMI-TRAILER MOUNTED FABRIC TANK (SMFT), WATER
PREVENTIVE MAINTENANCE CHECKS AND SERVICES (PMCS) PROCEDURES**

INITIAL SETUP:

Materials/Parts:

Brush, Scrub (WP 0033, Item 2)
Detergent, General Purpose (WP 0033, Item 4)

PMCS PROCEDURES

Table 1. Operator's Preventive Maintenance Checks and Services for SMFT.

Item No.	Interval	Item To Be Checked Or Serviced	Procedure	Equipment Not Ready/ Available If:
1	Before	Tank	Inspect for cuts, punctures and leaks.	Tank is cut, punctured or leaks.
2	Before	Filler/Discharge Assembly	 <p>a. Inspect filler/discharge assembly (1) for loose or missing cap screws, fittings and leaks.</p> <p>b. Inspect gate valve (2) for proper operation.</p> <p>c. Inspect pressure gauge (3) for damage and pressure reading.</p> <p>d. Inspect adapter shut off valve (4) opens and closes.</p>	<p>a. Cap screws or fittings are loose or missing, or filler/discharge assembly leaks.</p> <p>b. Gate valve does not function.</p> <p>c. Pressure gauge does not read pressure.</p> <p>d. Adapter valve does not open or close.</p>

Table 1. Operator's Preventive Maintenance Checks and Services for SMFT. (Cont)

Item No.	Interval	Item To Be Checked Or Serviced	Procedure	Equipment Not Ready/ Available If:
3	Before	Inspection Plate	 <p>Inspect inspection plate (1) for loose or missing cap screws and leaks.</p>	Cap screws or fittings are loose or missing or inspection plate leaks.
4	Before	Pressure Relief Valve	 <p>Inspect for missing valve cap (1) and leaks.</p>	Valve leaks.
5	Before	Tie Down Assembly	 <p>Inspect for damage to winches (1) and cut or frayed tie down strap and/or sleeve (2).</p>	Winch is damaged. Tie down strap is cut.
6	During	Semi Trailer and Tank Area	Inspect area around trailer and tank for sticks, stones or sharp objects that may cause punctures to tank.	
7	During	Tank Assembly	Inspect for cuts, punctures and leaks.	Tank is cut, punctured or leaks, or fittings leaks.
8	During	Tie Down Assembly	 <p>Inspect for winches (1) and tie down straps (2) for tightness. Tighten as required to hold tank in place.</p>	Tie down straps are loose.

Table 1. Operator's Preventive Maintenance Checks and Services for SMFT. (Cont)

Item No.	Interval	Item To Be Checked Or Serviced	Procedure	Equipment Not Ready/ Available If:
9	During	Pressure Gauge	Inspect pressure gauge reads pressure.	
10	After	Tank	Inspect for cuts, punctures and leaks.	Tank is cut, punctured or leaks.
11	After	Filler/Discharge Assembly	 <p>a. Inspect filler/discharge assembly (1) for loose or missing cap screws, fittings and leaks.</p> <p>b. Inspect gate valve (2) for proper operation.</p> <p>c. Inspect pressure gauge (3) for damage and pressure reading.</p> <p>d. Inspect adapter shut off valve (4) opens and closes.</p>	<p>a. Cap screws or fittings are loose or missing, or filler/discharge assembly leaks.</p> <p>b. Gate valve does not function.</p> <p>c. Pressure gauge does not read pressure.</p> <p>d. Adapter valve does not open or close.</p>
12	After	Inspection Plate	 <p>Inspect inspection plate (1) for loose or missing cap screws and leaks.</p>	Cap screws or fittings are loose or missing, or inspection plate leaks.

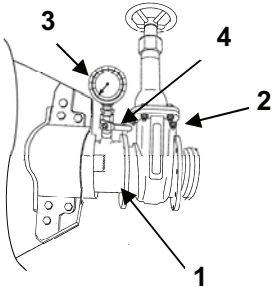
Table 1. Operator's Preventive Maintenance Checks and Services for SMFT. (Cont)

Item No.	Interval	Item To Be Checked Or Serviced	Procedure	Equipment Not Ready/ Available If:
13	After	Pressure Relief Valve	 <p>Inspect for missing valve cap (1) and leaks.</p>	Valve leaks.
14	After	Tie Down Assembly	 <p>Inspect for damage to winches (1) and cut or frayed tie down strap and/or sleeves (2).</p>	Winch is damaged. Tie down strap is cut.

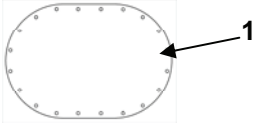
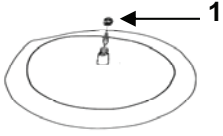
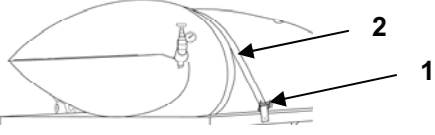
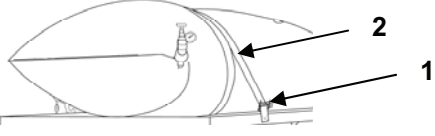
END OF WORK PACKAGE

OPERATOR
3K & 5K SEMI-TRAILER MOUNTED FABRIC TANK (SMFT), WATER
EMERGENCY REPAIR OF TANK

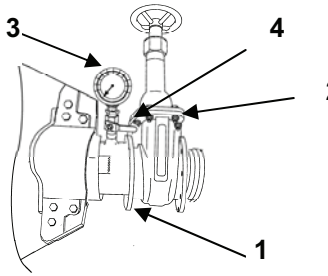
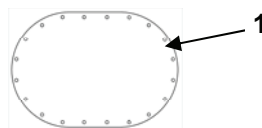
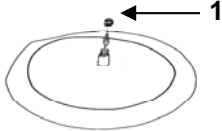
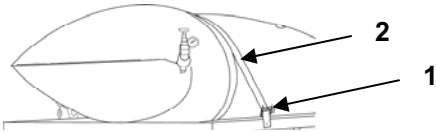
INITIAL SETUP:**Tools:**

Repair Kit (WP 0031, Item 3)

EMERGENCY REPAIRS

When holes are less than 2 inches (5.08cm), repair as follows:

SMFT Filled Using Wood Plug

1. Select wood plug (Figure 1, Item 1) as required:

<u>Hole Size</u>	<u>Plug</u>
Up to 3/8 in. (0.95 cm)	5/8 in. (1.59 cm)
3/8 to 1 in. (0.95 to 2.54 cm)	1-1/2 in. (3.8 cm)
1 to 1-1/2 in. (2.54 to 3.8 cm)	2 in. (5.08 cm)

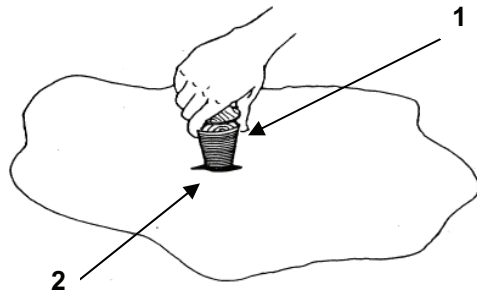

Figure 1. Wood Plug Installation.

2. Push small end of wood plug (Figure 1, Item 1) into hole (Figure 1, Item 2) and turn until tight. Leak should slow down and stop when plug is tightened.
3. Check wood plug (Figure 1, Item 1) during operation. If tank begins to leak, tighten wood plug.
4. When tank is emptied, replace wood plug (Figure 1, Item 1) with mechanical patch.

SMFT Empty Using Mechanical Patch**NOTE**

The repair kit contains mechanical patches to seal punctures, slits or tears up to 6 inches (15.24 cm).

1. Select mechanical patch as required:

Hole Size

Up to 1-7/8 in. (4.76 cm)
 1-7/8 to 3-7/8 in. (4.76 to 9.84 cm)
 3-7/8 to 6 in. (9.84 to 15/24 cm)

Plug

3in. (7.62 cm)
 5 in. (12.7 cm)
 7-1/2 in. (19.05 cm)

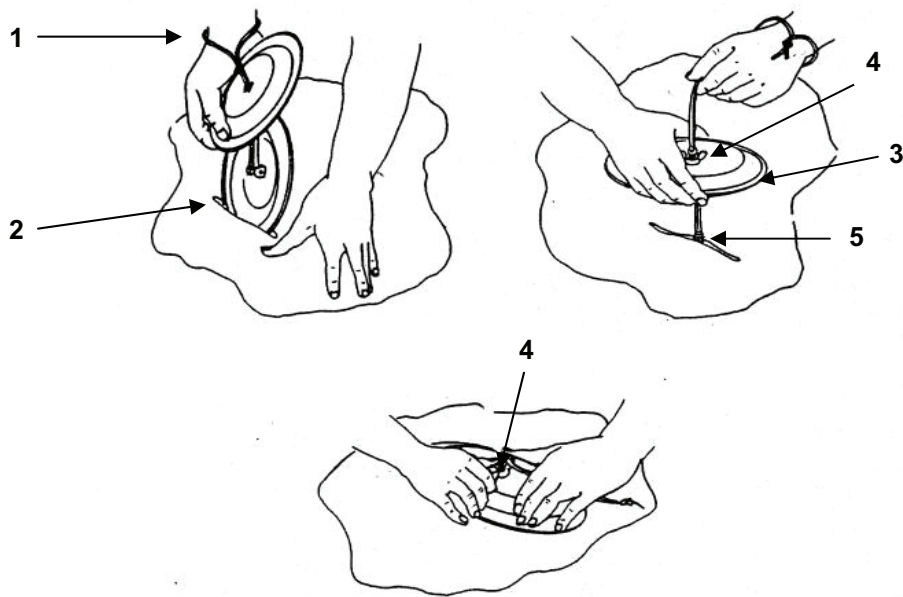

Figure 2. Mechanical Patch Installation.

2. Loop cord around wrist (Figure 2, Item 1) to prevent loss of plate into tank.
3. Insert bottom plate (Figure 2, Item 2) through hole and rotate until centered and length runs with hole. If plate does not fit through hole, use a knife to enlarge the hole equally on both sides until bottom plate fits through hole.
4. Pull bottom plate up against fabric and slide top plate (Figure 2, Item 3) and wing nut (Figure 2, Item 4) down cord and onto threaded stud (Figure 2, Item 5) of bottom plate.

CAUTION

Do not over tighten wing nut. Stud threads may strip or cause damage to tank fabric.

5. With plates aligned, tighten wing nut (Figure 2, Item 4) clamping the tank wall between the two plates. Tighten wing nut enough to stop the leak.
6. After tank has been filled, check for leaks and tighten mechanical patch as required.

END OF WORK PACKAGE

CHAPTER 5

FIELD MAINTENANCE INSTRUCTIONS
FOR
3K & 5K SEMI-TRAILER MOUNTED FABRIC TANK (SMFT), WATER

FIELD MAINTENANCE
3K & 5K SEMI-TRAILER MOUNTED FABRIC TANK (SMFT), WATER
SERVICE UPON RECEIPT

INITIAL SETUP:**Tools and Special Tools:**

- Tool Kit, General Mechanics (WP 0031, Item 1)
- Tire Valve Repair Tool (WP 0031, Item 2)
- Torque Wrench, 0-100 ft-lbs (WP 0031, Item 4)

Materials/Parts:

- Lint Free Rags (WP 0033, Item 5)
- Tape, Antiseize (WP 0033, Item 6)
- Compound, Antiseize (WP 0033, Item 3)
- Bleach, Laundry (WP 0033, Item 1)

Personnel Required:

- Four (4) (3K SMFT)
- Six (6) (5K SMFT)

UNPACKING

The SMFT is packaged and shipped in a container with fork lift capabilities for unloading and loading. After unloading unpack as follows:

1. Inspect crate (Figure 1, Item 1) for damage.

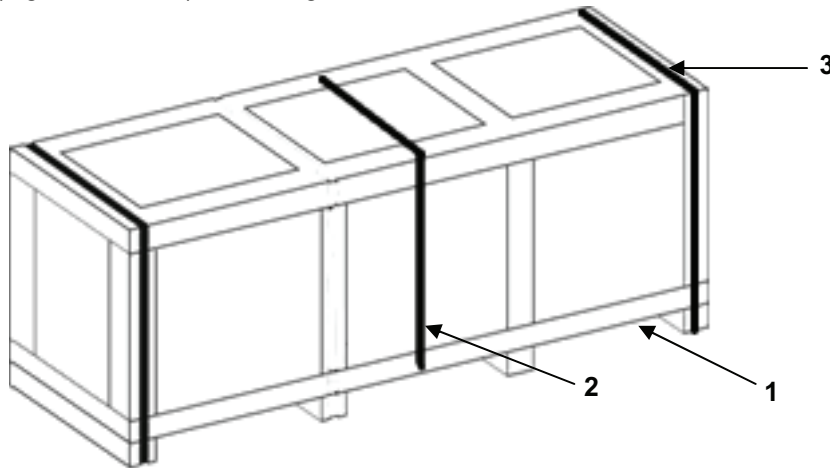

Figure 1. SMFT Crate.

2. Unload crate (Figure 1, Item 1) as near to trailer as possible.

NOTE

Crate should be retained for stowing tank when not in use.

3. Remove three (3) bands (Figure 1, Item 2) and remove top (Figure 1, Item 3).
4. Inspect equipment for damage incurred during shipment. If equipment has been damaged, report the damage on SF 361, Transportation Discrepancy Report.
5. Check the equipment against the packing slip to see if the shipment is complete. Report all discrepancies in accordance with the instructions of DA PAM 738-750.

6. From 5K tank crate, remove two (2) suction hoses (Figure 2, Item 1).
7. From 3K tank crate, remove four (4) suction hoses (Figure 2, Item 1).

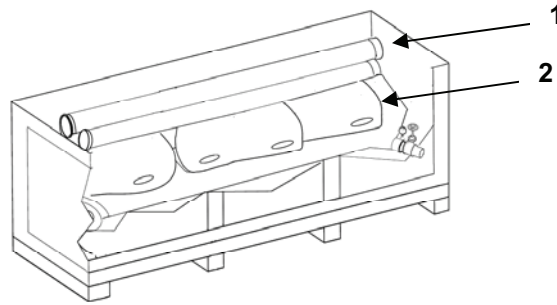

Figure 2. SMFT Crate Open.

8. Remove three (3) storage bags (Figure 2, Item 2) containing accessories.
9. Remove two (2) pads (Figure 3, Item 1) from crate.
10. Remove tie down straps with sleeves (Figure 3, Item 2), verifying four (4) straps for 3K SMFT and five (5) for 5K SMFT.
11. The following items are stowed in the storage bags and should be removed when required.
 - a. Remove winches (Figure 3, Item 3) verifying eight (8) winches for 3K SMFT and ten (10) for 5K SMFT.
 - b. Remove winch bar (Figure 3, Item 4).
 - b. Remove pressure gauge (Figure 3, Item 5), verifying it is not damaged.
 - c. From 3K crate, remove a coupling half quick disconnect (Figure 3, Item 6), pipe swing joint (Figure 3, Item 7), and a nozzle assembly (Figure 3, Item 8),

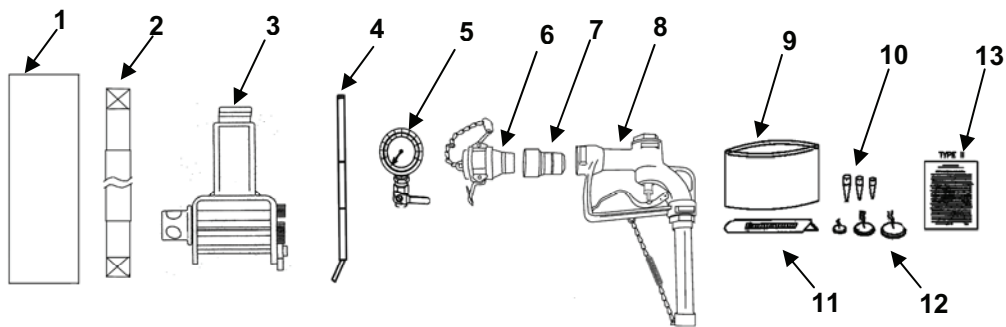

Figure 3. SMFT Accessories.

12. Inspect repair kit damage or missing components.
 - a. Ripped or dirty pouch (Figure 3, Item 9).
 - b. Three (3) wooden plugs for cracks, chips or gouges (Figure 3, Item 10).
 - c. Three (3) mechanical patches for cracks, bends or deterioration (Figure 3, Item 12).

- d. One knife (Figure 3, Item 11).
 - e. Tech data sheet (Figure 3, Item 13).
13. Place repair kit pouch (Figure 3, Item 9) with components in secure place until needed.

ASSEMBLY AND PREPARATION FOR USE

WARNING

Trailer must be level to prevent tank from rolling during operation, causing injury or death to personnel.

CAUTION

Remove all splinters, protruding nails and other foreign objects from trailer bed that could chafe or puncture tank.

Should trailer have center mounted shackles, rough bed, protruding boards and/or bolt heads, pads must be placed over these areas to prevent damage to tank.

Do not use trailer with four foot spacing between stake pockets, as tank can not be securely tied down.

1. Prepare flatbed trailer, M871 or M872 for 3K tanks or M872 for 5K tanks, by clearing trailer bed of splinters, protruding nails and other foreign objects that could chafe or puncture tank.

NOTE

Due to the different configurations of M871 and M872 trailers, tie down winches may have to be positioned in different stake pockets with tie down straps positioned accordingly. Attempt to repair any unusable stake pocket before electing to move to next available stake pocket.

The 3K tank will have four (4) tie down straps and eight (8) winches and the 5K tank will have five (5) tie down straps and ten (10) winches.

2. Place pads over center mounted shackles, rough bed, protruding boards and/or bolt heads, as required.
3. Position tie down straps with sleeves (Figure 4, Item 1) on trailer (Figure 4, Item 2) with even amount hanging from each side and approximately a three (3) foot space between sleeves (Figure 4, Item 3). Refer to Figure 5 for approximate tie down locations for different tanks and trailers.

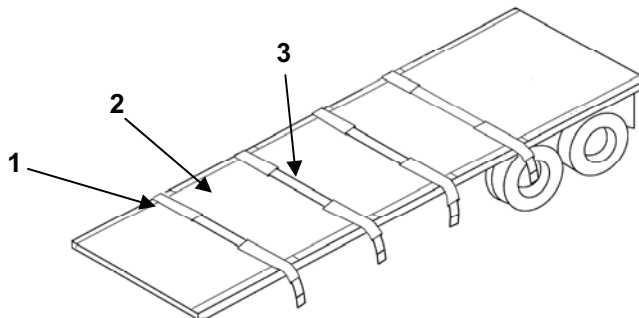
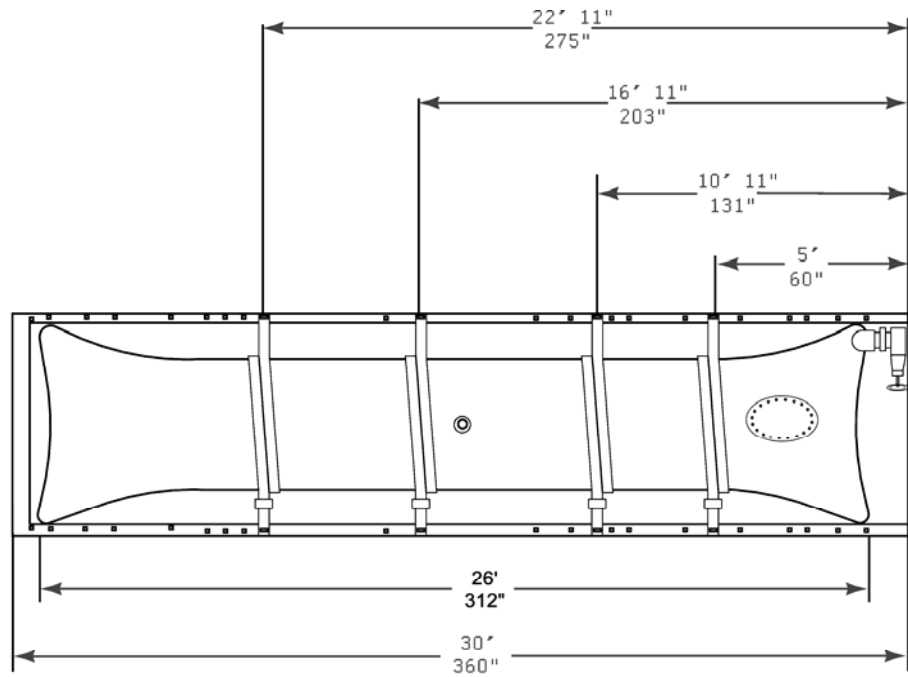
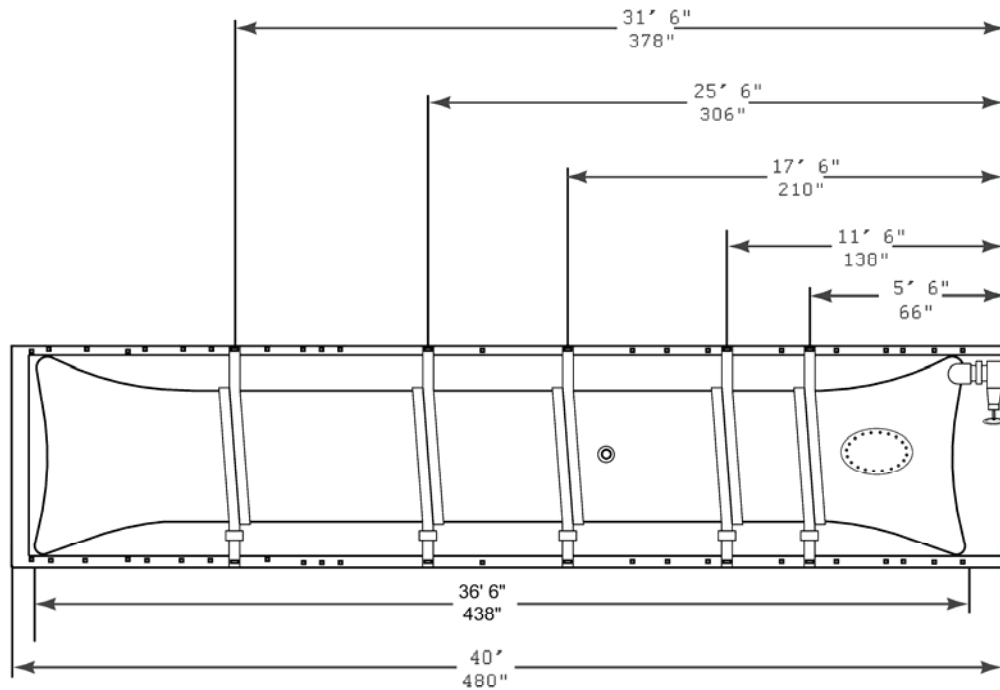

Figure 4. Positioning Tie Down Straps.



TYPICAL TIE DOWN LOCATIONS, 3K SMFT, M871 OR M872 TRAILER



TYPICAL TIE DOWN LOCATIONS, 5K SMFT, M872 TRAILER

Figure 5. Typical Tie Down Positions

WARNING

Lifting device must be capable of lifting 1000 lbs. to prevent injury or death to personnel.

- Using a suitable lifting device, attach to four (4) lifting straps (Figure 6, Item 1) and carefully lift tank (Figure 6, Item 2) out of crate (Figure 6, Item 3) and transport to trailer bed.

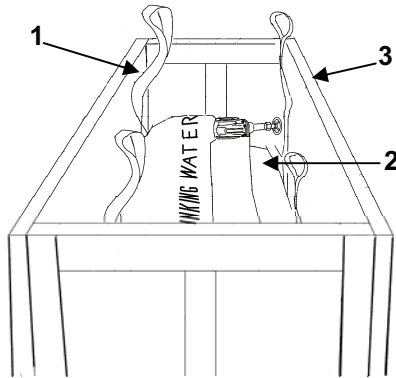

Figure 6. Lifting Tank.

WARNING

Manhandling of 3K SMFT requires four (4) persons and the 5K SMFT requires six (6) persons to prevent strain or injury to personnel.

- Position tank with protective flat bed cloth (Figure 7, Item 1), so first tank strap location is lined up with first stake pocket and filler/discharge assembly (Figure 7, Item 2) is at rear right corner of trailer.

CAUTION

Do not attach any mechanical device to tank for movement. Only use hands during unrolling and positioning of tank. Do not walk on tank unless wearing soft soled shoes clean of all abrasive materials. Damage to tank could occur.

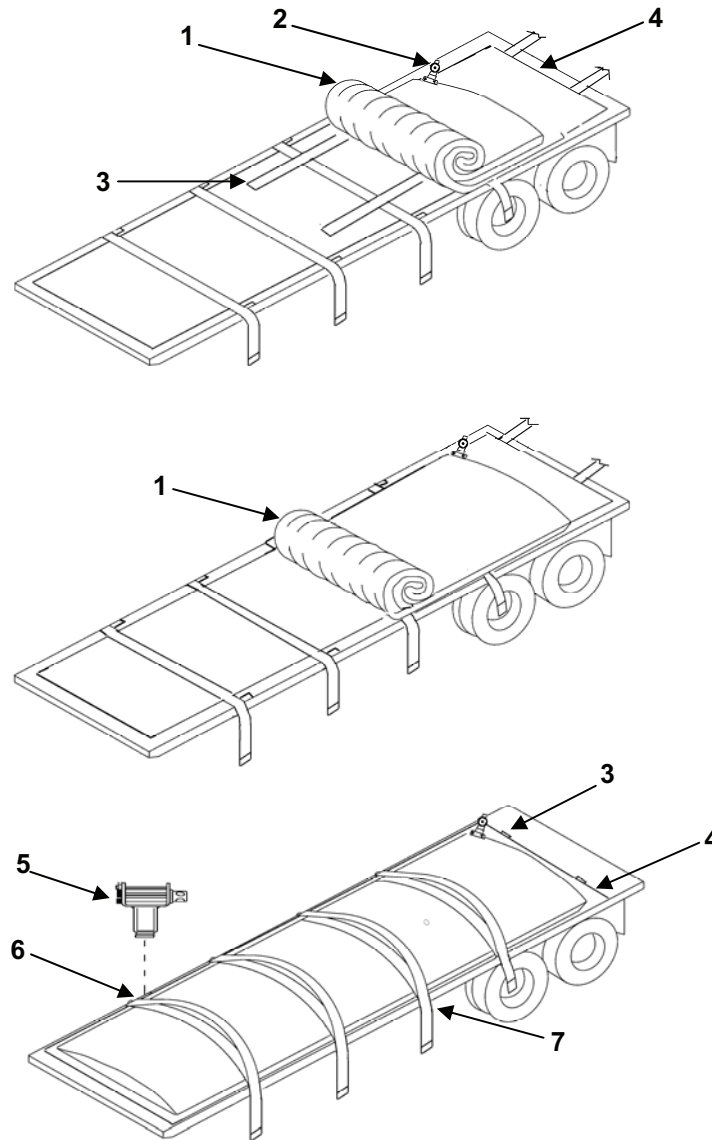

Figure 7. Positioning Tank on Trailer.

6. Lay lifting straps (Figure 7, Item 3) toward each end of trailer.

NOTE

During unrolling, visually inspect tank for cuts, tears, and material abrasions.

7. Using two personnel, completely unroll tank with protective flat bed cloth (Figure 7, Item 1) forward.
8. Position tank so it is completely on flat bed protective cloth (Figure 7, Item 4).
9. Fold lifting straps (Figure 7, Item 3), at rear of trailer and place under flat bed protective cloth (Figure 7, Item 4).

CAUTION

When full, ends of the tank should not rub against the forward trailer bulkhead or have sides hanging over trailer. Damage to the tank could occur.

10. Install winches (Figure 7, Item 5) in trailer stake pocket (Figure 7, Item 6).
11. Adjust tie down straps with sleeves (Figure 7, Item 7) so they are flat and in line with the winch (Figure 7, Item 5) positions on tank.
12. On each side of the trailer, place free ends of tie down straps with sleeves (Figure 7, Item 7) across tank to opposite side of trailer.

NOTE

Tie down straps must be placed over top of winch into take up mechanism to provide proper holding of tank.

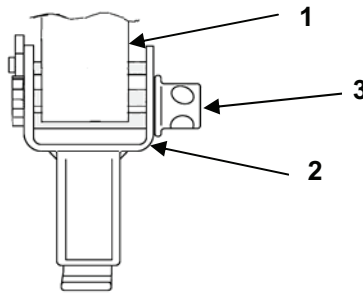

Figure 8. Feeding Tie Down Strap into Winch.

13. Feed free end of tie down strap (Figure 8, Item 1) over top of winch (Figure 8, Item 2) into take up mechanism approximately one (1) foot.
14. Make three (3) turns counterclockwise on winch take up mechanism (Figure 8, Item 3) by hand.

FILLING THE TANK**NOTE**

Before filling tank, filler/discharge top clamp cap screws should be checked for proper torque.

The outlet seal in a new tank will “cold flow” under pressure and torque will drop. It is critical that a tightening sequence be from side to side as each bolt influences torque of adjacent bolts. The cap screws should be retorqued to specifications after first filling cycle and then periodically until tank material has set and torque does not drop below specific torque value.

If leakage is noted at round clamp area after retorquing, refer to Field Troubleshooting (WP 0008).

1. Check torque on six (6) cap screws (Figure 9, Item 1) to be 85.0 ± 5 ft lbs (115 ± 7 N•m). Retorque as required.
2. Remove pressure gauge (Figure 9, Item 2) from storage bag.

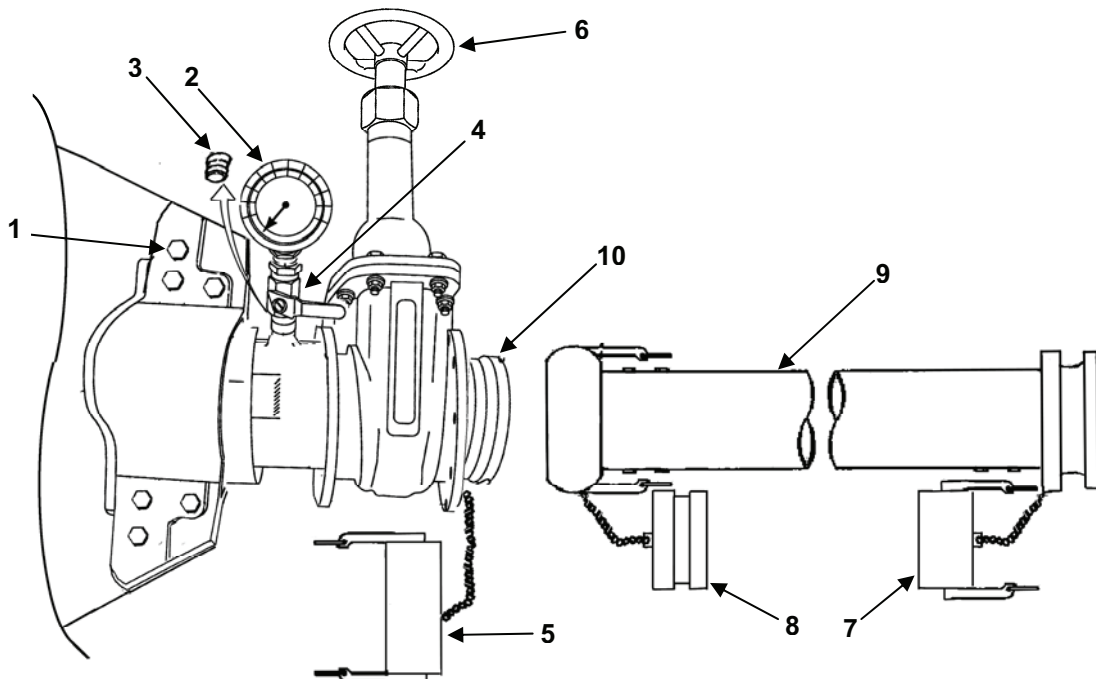

Figure 9. Filler/Discharge Assembly.

3. Remove plug (Figure 9, Item 3) from adapter shutoff valve (Figure 9, Item 4). Place plug in secure place, to be installed when removing pressure gauge.
4. Apply antiseize tape to pressure gage (Figure 9, Item 2) threads and install into adapter shutoff valve (Figure 9, Item 4).
5. Open adapter shutoff valve (Figure 9, Item 4).

NOTE

Before using tank for the first time or after prolonged storage, flush tank with solution of 0.5 gallons of bleach mixed in 250 gallons of fresh water. Surge cleaning solution by walking back and forth on tank. Rinse tank with 250 gallons of clean water to remove bleach taste. When cleaning is complete, close tank valve immediately to hermetically seal out contaminants.

6. Remove quick disconnect cap (Figure 9, Item 5).
7. Open filler/discharge gate valve (Figure 9, Item 6) and ensure all air has been expelled from tank, then close gate valve.
8. Remove quick disconnect cap (Figure 9, Item 7) and plug (Figure 9, Item 8) from 4-inch suction hose (Figure 9, Item 9) and attach hose to water source.
9. Open water source valve and purge 4-inch suction hose (Figure 9, Item 9) of air.
10. Once water is discharged from hose, shut off water source valve.
11. Attach 4-inch suction hose (Figure 9, Item 9) to quick disconnect coupling half (Figure 9, Item 10) and lock arms into position.
12. Open water source valve.
13. Open filler/discharge gate valve (Figure 9, Item 6).

NOTE

To avoid inaccurate reading, shut off gate valve each time a pressure reading is taken.

14. Fill tank until approximately 2 - 3 feet high and begin monitoring pressure gauge, by shutting off filler/discharge gate valve (Figure 9, Item 6) and take a pressure reading.
15. Continue filling tank and take pressure readings until pressure gauge reads between 2 – 2.5 psi (14 – 17 kPa), then shut off filler/discharge gate valve (Figure 9, Item 6).
16. Remove dust cap (Figure 10, Item 7) from relief valve on top of tank and depress valve stem until water flows from valve.
17. Replace dust cap (Figure 10, Item 7).

NOTE

Tie down straps must be tightened uniformly to ensure there is no movement of tank once filled. Should tank not appear uniform, tie down straps must be loosened and retightened accordingly.

18. Using winch bar (Figure 10, Item 2), uniformly tighten all tie downs straps (Figure 10, Item 3), ensuring straps wind true and flat, until tie down straps are taut. Tank pressure may increase.

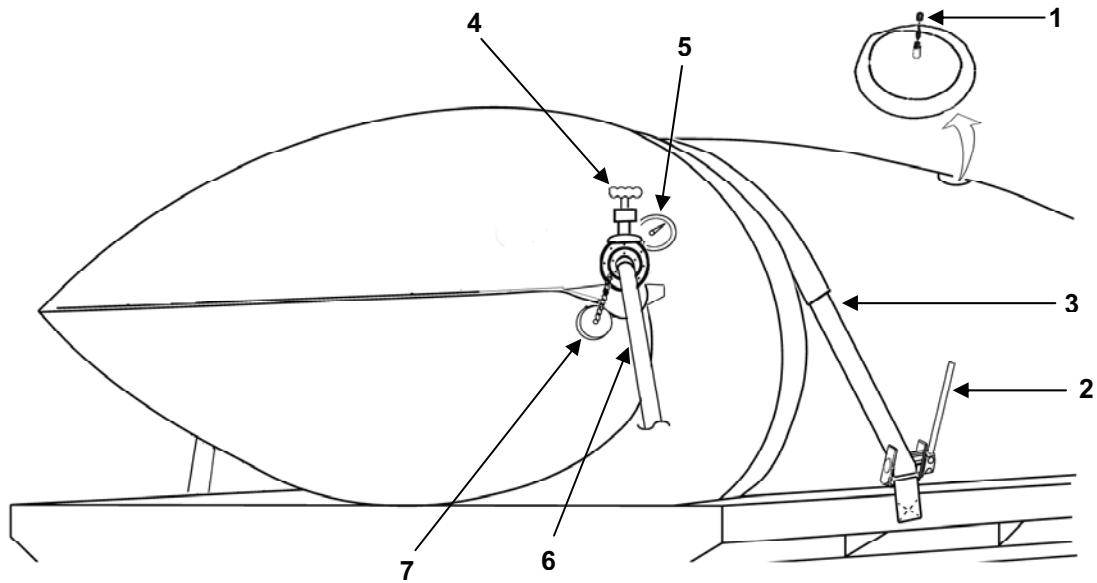

Figure 10. Bleeding Relief Valve.

CAUTION

Slowly open filler/discharge valve when beginning to fill tank, to avoid high pressure water being applied and damaging the tank.

NOTE

Shutting off water source valve first, then filler/discharge assembly gate valve, will create a low pressure in the suction hose.

19. Slowly open filler/discharge gate valve (Figure 10, Item 4) and continue filling tank until pressure gauge (Figure 10, Item 5) reads between 4 – 6 psi (21 -41 kPa), then shut off water source valve.
20. Shut off filler/discharge gate valve (Figure 10, Item 4).
21. Remove suction hose (Figure 10, Item 6) from water source and filler/discharge gate valve (Figure 10, Item 4).
22. Install quick disconnect cap (Figure 10, Item 7) on filler/discharge gate valve (Figure 10, Item 4) with locking arms in horizontal position.

NOTE

When not in use, check tie downs every two (2) hours for tightness. During use, tighten tie downs as required to maintain operating pressure.

It is normal for tank pressure to decrease from 5 psi to 3 psi after normal filling, due to relaxation of tank fabric material.

PREPARATION FOR MOVEMENT

WARNING

Tank must be transported only when completely full or completely empty to prevent injury to personnel.

Full Tank

1. When tank is full, prior to movement, ensure tie down straps are secure and tight.

CAUTION

Quick disconnect cap locking handles must be placed in horizontal position to prevent damage to cap during emergency stops.

2. Ensure filler/discharge (Figure 10, Item 4) quick disconnect cap (Figure 10, Item 7) handles are in horizontal position.
3. Obtain pipe plug (Figure 11, Item 1).
4. Remove pressure gauge (Figure 11, Item 2) and install pipe plug (Figure 11, Item 1).

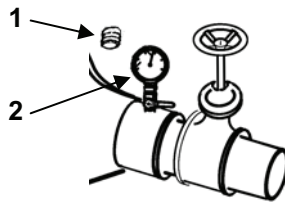

Figure 11. Removing Pressure Gauge.

5. Ensure all components have been properly stowed and secured.

WARNING

Should an emergency stop or dramatic maneuver be made during transportation, stop and check tank position, tie down straps position and tension to prevent injury to personnel should tank become loose.

6. After first 2 – 5 miles of travel, stop and check tie downs for security and that the tank has not shifted. Pressure gauge should read between 4 – 6 psi (21 - 41 kPa). If not, tighten tie downs uniformly until pressure reads between 4 – 6 psi (21 -41 kPa).
7. Repeat steps 5 and 6 after 10 – 15 miles (16 – 24 km) of travel and after 30 – 35 (48 – 56 km) miles of travel.
8. If no change has been noted, no further inspection is required.

Empty Tank

1. When tank is empty, prior to movement, roll tank and protective flat bed cloth manually, making first roll circular and as tight as possible. Secure latch to trailer.
2. Ensure all components have been properly stowed and secured.

DRAINING TANK**WARNING**

The tank can only be emptied by gravity or suction pump. Use of air pressure to unload tank is not authorized as it may cause the tank to burst under pressure and cause injury to personnel.

Gravity Draining

1. Raise forward end and left side of trailer bed 8 - 10 inches higher than filler/discharge gate valve (Figure 12, Item 1) end.
2. Connect 4-inch suction hose (Figure 12, Item 2) to quick disconnect coupling half (Figure 12, Item 3) and position hose to discharge area.
3. Close adapter shutoff valve (Figure 12, Item 4).
4. Open filler/discharge gate valve (Figure 12, Item 1) to start flow.

NOTE

When completely full, tank will drain in less than 30 minutes.

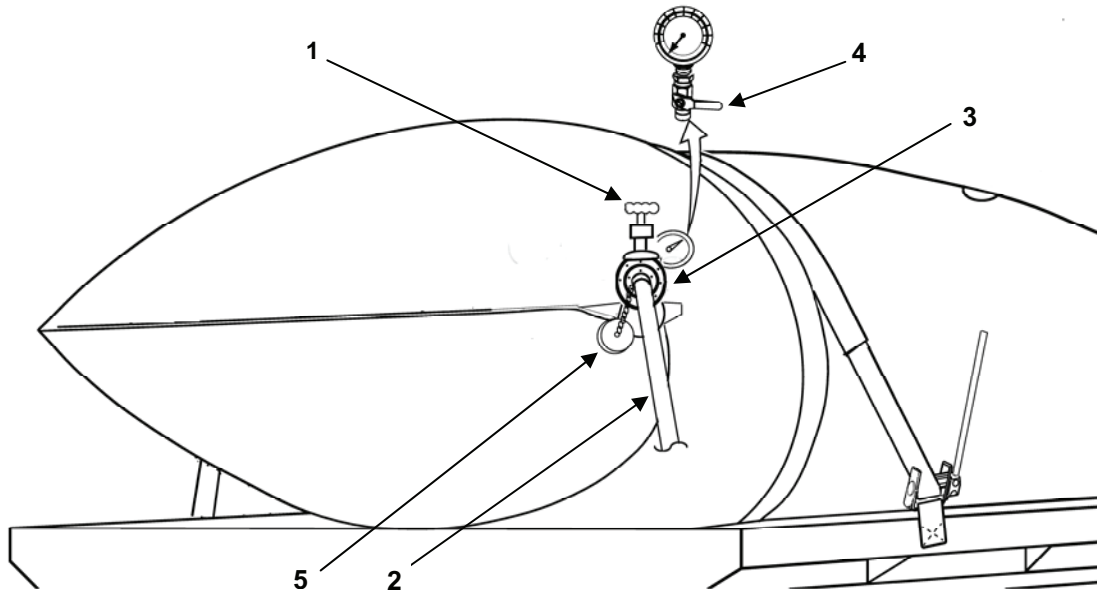

Figure 12. Draining Tank.

4. After tank has drained completely, close filler/discharge gate valve (Figure 12, Item 1).
5. Disconnect suction hose (Figure 12, Item 2) from quick disconnect coupling half (Figure 12, Item 3).
6. Install quick disconnect cap (Figure 12, Item 5) on filler/discharge gate valve (Figure 12, Item 1) with handles in horizontal position.

Pump Draining

1. Raise forward end and left side of trailer bed 8 - 10 inches higher than filler/discharge gate valve (Figure 12, Item 1) end.
2. Connect 4-inch suction hose (Figure 12, Item 2) to quick disconnect coupling half (Figure 12, Item 3) and position hose to discharge area
3. Connect opposite end of 4-inch suction hose (Figure 12, Item 2) to pump.
4. Close adapter shutoff valve (Figure 12, Item 4).
5. Open filler/discharge gate valve (Figure 12, Item 1).
6. Start pump and open pump valve to begin draining.
7. After tank has drained completely, close filler/discharge gate valve (Figure 12, Item 1).
8. Close pump valve
9. Disconnect 4-inch suction hose (Figure 12, Item 2) from quick disconnect coupling half (Figure 12, Item 3).
10. Install quick disconnect cap (Figure 12, Item 5) on filler/discharge gate valve (Figure 12, Item 1) with handles in horizontal position.
11. Disconnect 4-inch suction hose (Figure 12, Item 2) from pump.

REPACKING**CAUTION**

Ensure tank is completely dry before folding. Water will create mildew, decreasing life of tank if not completely dry.

1. Remove 20 bolts (Figure 13, Item 1) from inspection plate (Figure 13, Item 2). Remove plate.

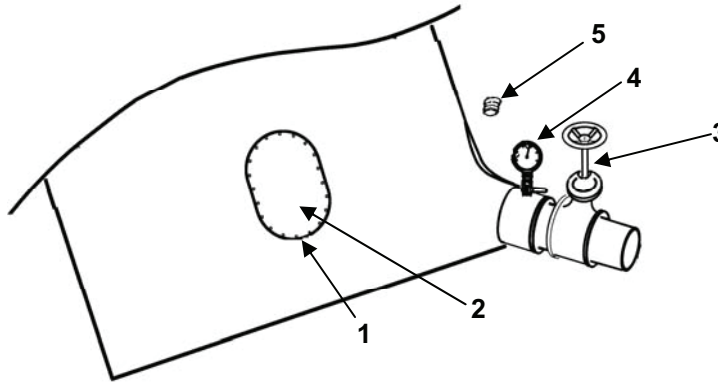

Figure 13. Removing Inspection Plate and Pressure Gauge.

WARNING

The tank is a permit required confined space. Do not enter tank as injury or death to personnel may result.

2. Air dry tank through filler/discharge valve (Figure 13, Item 3). Apply high volume low pressure air into tank to inflate.
3. Install inspection plate (Figure 13, Item 2) using 20 bolts (Figure 13, Item 1).
4. Remove pressure gauge (Figure 13, Item 4) from adapter shutoff valve, pad and stow in storage bag.
5. Install plug (Figure 13, Item 5) into adapter shutoff valve.

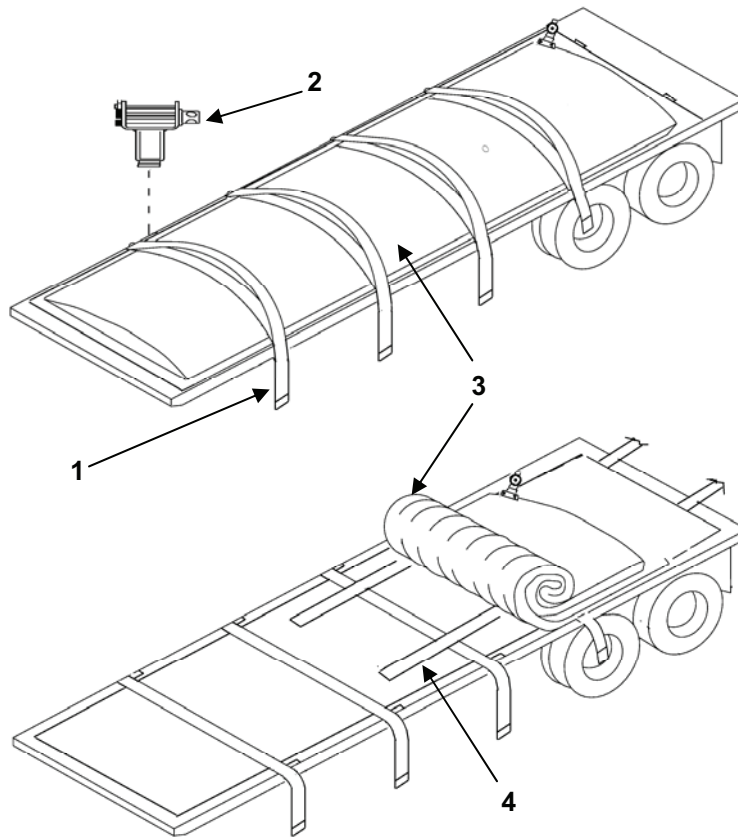

Figure 14. Removing Tie Downs, Winches and Rolling Tank.

6. Remove tie downs (Figure 14, Item 1) from winch (Figure 14, Item 2).
7. Roll and stow tie downs with sleeves (Figure 14, Item 1).
8. Remove winches (Figure 14, Item 2) and stow in storage bag.

CAUTION

Ensure top of tank is clear of any debris that may have accumulated before rolling. Debris can cause damage to tank.

9. Remove any debris from top of tank (Figure 14, Item 3).
10. Roll tank (Figure 14, Item 3) with protective flat bed cloth manually as tight as possible.
11. Once rolled, lifting handles (Figure 14, Item 4) should be in position to lift tank.

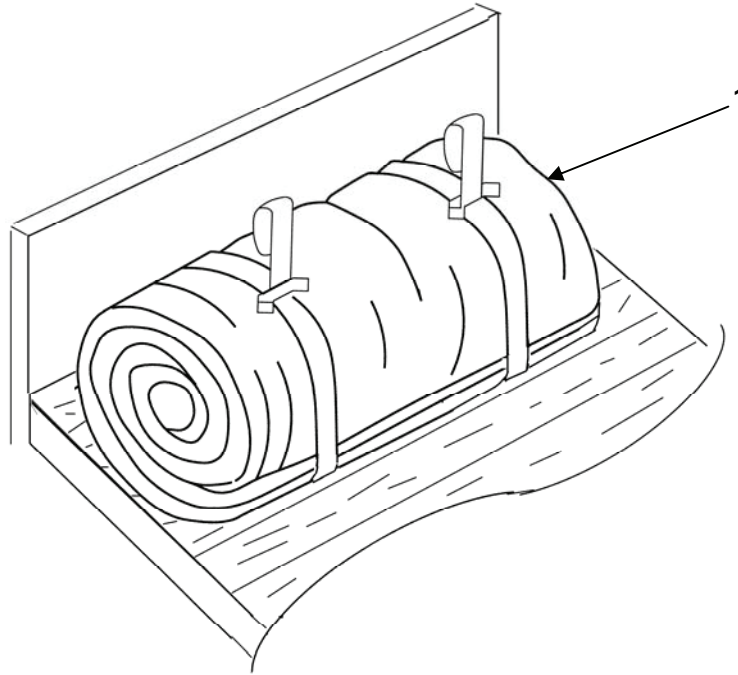

Figure 15. Stowed Tank on Trailer Bed.

12. Place rolled tank (Figure 15, Item 1) on forward end of trailer and secure in place.
13. Remove and stow pads from trailer, if used.
14. Stow tie downs with sleeves, hoses and storage bags with components.

END OF WORK PACKAGE

**FIELD MAINTENANCE
FILLER/DISCHARGE ASSEMBLY
INSPECT/REPLACE/REPAIR**

INITIAL SETUP:

Tools:

- Tool Kit, General Mechanics (WP 0031, Item 1)
- Torque Wrench, 0-100 ft-lbs (WP 0031, Item 4)

Materials/Parts:

- Brush, Scrub (WP 0033, Item 2)
- Detergent, General Purpose (WP 0033, Item 4)
- Rag, Wiping (WP 0033, Item 5)
- Antiseize Tape (WP 0033, Item 6)
- Antiseize Compound (WP 0033, Item 3)
- Lock Washers (WP 0034, Item 1)
- Gasket (WP 0034, Item 2)
- Gasket (WP 0034, Item 3)
- Packing (WP 0034, Item 6)

Equipment Condition:

- Tank drained (WP 0005)

REMOVAL

Pressure Gauge

NOTE

To remove pressure gauge, tank does not need to be drained if adapter valve is closed.

1. Close adapter valve handle (Figure 1, Item 1).
2. Hold adapter valve (Figure 1, Item 2).
3. Remove pressure gauge (Figure 1, Item 3).

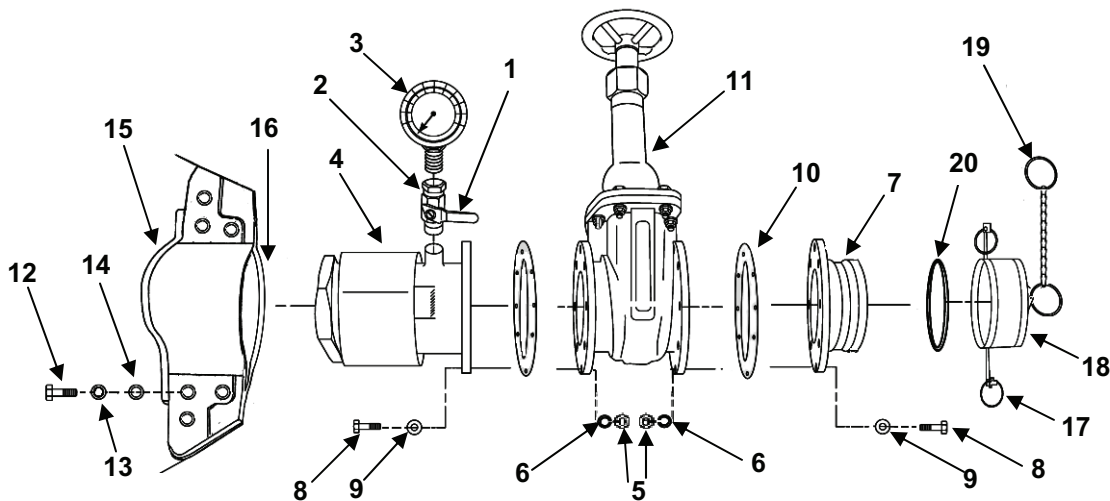

Figure 1. Disassembly of Filler/Discharge Assembly.

Adapter Valve

1. Remove pressure gauge (Figure 1, Item 3).
2. Remove adapter valve (Figure 1, Item 2) from flange casting (Figure 1, Item 4).

Coupling Half, Quick Disconnect

1. Remove eight (8) nuts (Figure 1, Item 5) with lock washers (Figure 1, Item 6). Discard lock washers.
2. Hold coupling half (Figure 1, Item 7) and remove eight (8) cap screws (Figure 1, Item 8) with flat washers (Figure 1, Item 9).
3. Remove and discard gasket (Figure 1, Item 10).

Gate Valve

1. Remove eight (8) nuts (Figure 1, Item 5) with lock washers (Figure 1, Item 6). Discard lock washers.
2. Hold coupling half (Figure 1, Item 7) and remove eight (8) cap screws (Figure 1, Item 8) with flat washers (Figure 1, Item 9).
3. Remove and discard gasket (Figure 1, Item 10).
4. Holding gate valve (Figure 1, Item 11), remove eight (8) nuts (Figure 1, Item 5) with lock washers (Figure 1, Item 6). Discard lock washers.
5. Remove gate valve (Figure 1, Item 11) with cap screws (Figure 1, Item 8) and flat washers (Figure 1, Item 9) from flange casting (Figure 1, Item 4).
6. Remove and discard gasket (Figure 1, Item 10).

Clamp, Top and Bottom

1. Remove six (6) cap screws (Figure 1, Item 12) with flat washers (Figure 1, Item 13) and packing with retainer (Figure 1, Item 14) from top clamp (Figure 1, Item 15). Discard packing with retainer.
2. Remove top clamp (Figure 1, Item 15) and bottom clamp (Figure 1, Item 16).

Flange Casting with Seal**NOTE**

If replacing flange casting with seal, perform step one.

1. Remove adapter valve (Figure 1, Item 2) with pressure gauge (Figure 1, Item 3) from flange casting (Figure 1, Item 4).
2. Holding gate valve (Figure 1, Item 11), remove eight (8) nuts (Figure 1, Item 5) with lock washers (Figure 1, Item 6) and eight (8) cap screws (Figure 1, Item 8) and flat washers (Figure 1, Item 9) from flange casting (Figure 1, Item 4). Discard lock washers.
3. Remove gate valve (Figure 1, Item 11).

4. Remove six (6) cap screws (Figure 1, Item 12) with flat washers (Figure 1, Item 13) and packing with retainer (Figure 1, Item 14) from top clamp (Figure 1, Item 15). Discard packing with retainer.
5. Remove bottom clamp (Figure 1, Item 16).
6. Remove flange casting (Figure 1, Item 4).

Quick Disconnect Cap

1. Open quick disconnect (Figure 1, Item 17) and remove cap (Figure 1, Item 18).
2. Remove chain ring (Figure 1, Item 19) from coupling half (Figure 1, Item 7).
3. Replace gasket (Figure 1, Item 20) as required.

CLEANING

Clean all parts, sealing surfaces and threaded areas with mild soap and water solution. Remove any foreign matter with stiff bristle brush. Wipe parts dry with clean rags.

INSPECTION

1. Inspect all components for cracks, dents, stripped threads, wear and leaks.
2. Inspect pressure gauge (Figure 1, Item 3) for cracked or broken faceplate and bent indicator.
3. Check pressure gauge operation by blowing into end of gauge. Pressure should read between 2.0 to 2.5 psi (14 to 17 kPa).
4. Inspect flange casting (Figure 1, Item 4) seal, top clamp (Figure 1, Item 15) and bottom clamp (Figure 1, Item 16) for leaks.

REPAIR

1. Repair consists of replacing components that are damaged.
2. Replace pressure gauge if pressure test reading is below 2.0 psi (14 kPa).

INSTALLATION

Quick Disconnect Cap

1. Connect chain ring (Figure 2, Item 19) to coupling half (Figure 2, Item 7).
2. Install new gasket (Figure 2, Item 20), as required.
3. Install cap (Figure 2, Item 18), close quick disconnect (Figure 2, Item 17).

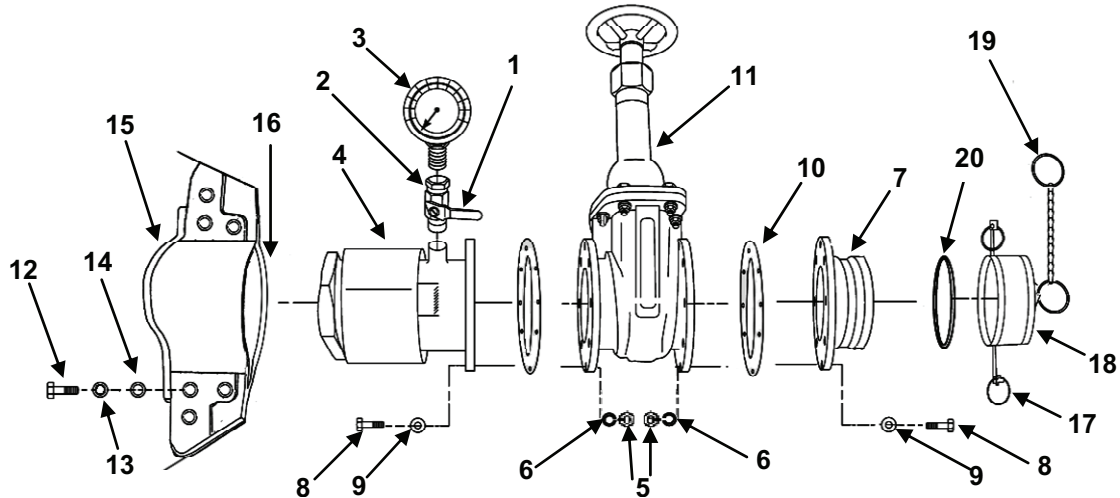

Figure 2. Assembly of Filler/Discharge Assembly.

Flange Casting with Seal

1. Install flange casting (Figure 2, Item 4) into tank opening. Ensure seal mates with tank mounting area.
2. Position bottom clamp (Figure 2, Item 16) and top clamp (Figure 2, Item 15) in place, aligning holes with tank flange mounting holes.
3. Install flat washer (Figure 2, Item 13) and new packing with retainer (Figure 2, Item 14) on to six (6) cap screws (Figure 2, Item 12).
4. Apply antiseize compound to six (6) cap screws (Figure 2, Item 12) and install into top clamp (Figure 2, Item 15). Alternately tighten from side to side until snug.

NOTE

When torquing cap screws, remember sequence so each cap screw can be rechecked in same sequence.

5. Alternately torque cap screws (Figure 2, Item 12) from side to side to 85.0 ± 5 ft lbs (115 ± 7 N•m).
6. Recheck each cap screw to ensure torque is at 85.0 ± 5 ft lbs (115 ± 7 N•m).
7. Apply antiseize tape to adapter valve (Figure 2, Item 2) threads.
8. Install adapter valve (Figure 2, Item 2) with pressure gauge (Figure 2, Item 3) into flange casting (Figure 2, Item 4).
9. Install two (2) cap screws (Figure 2, Item 8) with flat washers (Figure 2, Item 9) into each side of flange casting (Figure 2, Item 4).
10. Install new gasket on two (2) cap screws (Figure 2, Item 8).
11. Position gate valve (Figure 2, Item 11) on to flange casting (Figure 2, Item 4) aligning holes.

12. Install eight (8) cap screws (Figure 2, Item 8) with flat washers (Figure 2, Item 9) into flange casting (Figure 2, Item 4) and install six (6) new lock washers (Figure 2, Item 6) and nuts (Figure 2, Item 5). Alternately crisscross tighten nuts until snug.
13. Torque nuts to 35 ft-lbs (47 N*m) maximum.

Clamp, Top and Bottom

1. Ensure flange casting (Figure 2, Item 4) seal is properly positioned in tank flange mounting area.
2. Position bottom clamp (Figure 2, Item 16) and top clamp (Figure 2, Item 15) to align holes with tank flange mounting area holes.
3. Install flat washer (Figure 2, Item 13) and new packing with retainer (Figure 2, Item 14) on to six (6) cap screws (Figure 2, Item 12).
4. Apply antiseize compound to six (6) cap screws (Figure 2, Item 12) and install into top clamp (Figure 2, Item 15). Alternately tighten from side to side until snug.

NOTE

When torquing cap screws, remember sequence so each cap screw can be rechecked in same sequence.

5. Alternately torque cap screws (Figure 2, Item 12) from side to side to 85.0 ± 5 ft lbs (115 ± 7 N*m).
6. Recheck each cap screw to ensure torque is at 85.0 ± 5 ft lbs (115 ± 7 N*m).

Gate Valve

1. Install two (2) cap screws (Figure 2, Item 8) with flat washers (Figure 2, Item 9) into each side of flange casting (Figure 2, Item 4).
2. Install new gasket (Figure 2, Item 10) on two (2) cap screws (Figure 2, Item 8).
3. Position gate valve (Figure 2, Item 11) on to flange casting (Figure 2, Item 4) aligning holes.
4. Install remaining six (6) cap screws (Figure 2, Item 8) with flat washers (Figure 2, Item 9) into flange casting (Figure 2, Item 4) and install eight (8) new lock washers (Figure 2, Item 6) and nuts (Figure 2, Item 5). Alternately crisscross tighten nuts until snug.
5. Install two (2) cap screws (Figure 2, Item 8) with flat washers (Figure 2, Item 9) into each side of coupling half (Figure 2, Item 7).
6. Install new gasket (Figure 2, Item 10) on two (2) cap screws (Figure 2, Item 8).
7. Position coupling half (Figure 2, Item 7) on to gate valve (Figure 2, Item 11) aligning holes.
8. Install remaining six (6) cap screws (Figure 2, Item 8) with flat washers (Figure 2, Item 9) into coupling half (Figure 2, Item 7) and install eight (8) new lock washers (Figure 2, Item 6) and nuts (Figure 2, Item 5). Alternately crisscross tighten nuts until snug.
9. Torque cap screws to 35 ft-lbs (47 N*m) maximum.

Coupling Half, Quick Disconnect

1. Install two (2) cap screws (Figure 2, Item 8) with flat washers (Figure 2, Item 9) into each side of coupling half (Figure 2, Item 7).
2. Install new gasket (Figure 2, Item 10) on two (2) cap screws.
3. Position coupling half (Figure 2, Item 7) on to gate valve (Figure 2, Item 11) aligning holes.
4. Install remaining six (6) cap screws (Figure 2, Item 8) with flat washers (Figure 2, Item 9) into coupling half (Figure 2, Item 7) and install eight (8) new lock washers (Figure 2, Item 6) and nuts (Figure 2, Item 5). Alternately crisscross tighten nuts until snug.
5. Torque cap screws to 35 ft-lbs (47 N*m) maximum.

Adapter Valve

1. Apply antiseize tape to adapter valve (Figure 2, Item 2) threads.
2. Install adapter valve (Figure 2, Item 2) into flange casting (Figure 2, Item 4).

Pressure Gauge

1. Apply antiseize tape to pressure gauge (Figure 2, Item 3) threads.
2. Holding adapter valve (Figure 2, Item 2) install pressure gauge (Figure 2, Item 3).

END OF WORK PACKAGE

**FIELD MAINTENANCE
INSPECTION PLATE
INSPECT/REPLACE**

INITIAL SETUP:**Tools:**

- Tool Kit, General Mechanics (WP 0031, Item 1)
- Torque Wrench, 0-100 ft-lbs (WP 0031, Item 4)

Materials/Parts:

- Brush, Scrub (WP 0033, Item 2)
- Detergent, General Purpose (WP 0033, Item 4)
- Rag, Wiping (WP 0033, Item 5)
- O-ring (WP 0034, Item 4)

Equipment Condition:

- Tank drained (WP 0005)
-

REMOVAL

1. Remove 20 bolts (Figure 1, Item 1) with flat washers (Figure 1, Item 2).
2. Remove inspection plate (Figure 1, Item 3).
3. Remove and discard o-ring (Figure 1, Item 4).

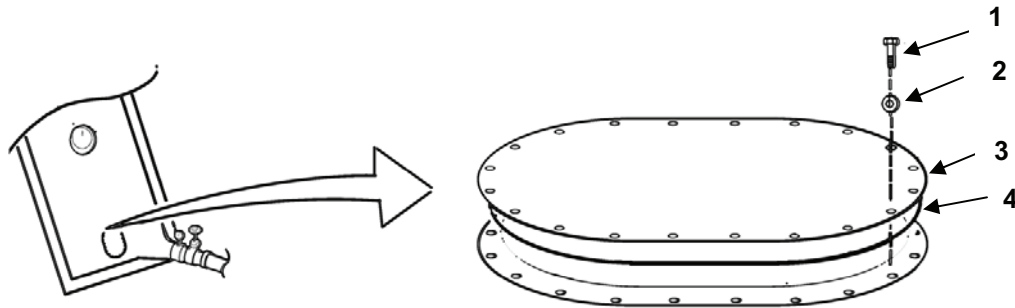

Figure 1. Inspection Plate.

CLEANING

Clean all parts, sealing surfaces and threaded areas with mild soap and water solution. Remove any foreign matter with stiff bristle brush. Wipe parts dry with clean rags.

INSPECTION

1. Inspect all components for cracks, gouges, stripped threads and wear.
2. Inspect seals for cracks, tears and rotting.

REPAIR

Repair consists of replacing o-ring.

INSTALLATION

1. Install new o-ring (Figure 1, Item 4).
2. Install inspection plate (Figure 1, Item 3).
3. Install 20 bolts (Figure 1, Item 1) with flat washers (Figure 1, Item 2) hand tight. Tighten bolts in crisscross pattern and torque to 10 ft lb (13.6 N*m) maximum.

END OF WORK PACKAGE

**FIELD MAINTENANCE
VALVE CAP AND CORE
INSPECT/REPAIR/REPLACE**

INITIAL SETUP:**Tools:**

Repair Tool, Pneumatic Tire Valve (WP 0031, Item 2)

REMOVAL

1. Remove valve cap (Figure 1, Item 1).

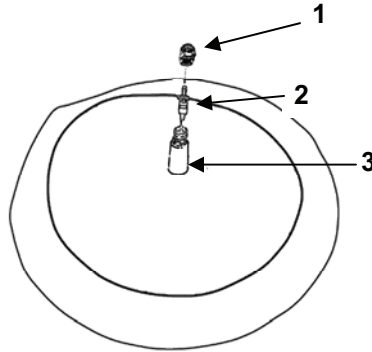

Figure 1. Valve Cap and Core.

CAUTION

Ensure bleed valve insert removal tool is clean of all dirt and foreign substance before inserting into valve stem. Dirt or foreign substance could damage valve core seal and cause leaks.

2. Using tire valve repair tool, remove and discard valve core (Figure 1, Item 2).

INSPECTION

1. Inspect valve stem (Figure 1, Item 3) for cracks, deterioration or stripped threads.
2. Inspect valve cap (Figure 1, Item 1) for cracks.

REPAIR

Repair consists of replacing valve core.

INSTALLATION

1. Using tire valve repair tool, install new valve core (Figure 1, Item 2).
2. Install valve cap (Figure 1, Item 1).

END OF WORK PACKAGE

**FIELD MAINTENANCE
HOSE ASSEMBLY
INSPECT/REPLACE/REPAIR**

INITIAL SETUP:**Tools:**

Tool Kit, General Mechanics (WP 0031, Item 1)

Materials/Parts:

Gasket (WP 0034, Item 3)

REMOVAL**Quick Disconnect Cap**

1. Open quick disconnect (Figure 1, Item 1) and remove quick disconnect cap (Figure 1, Item 2) from hose (Figure 1, Item 3).
2. Remove chain ring (Figure 1, Item 4) from quick disconnect cap (Figure 1, Item 2).

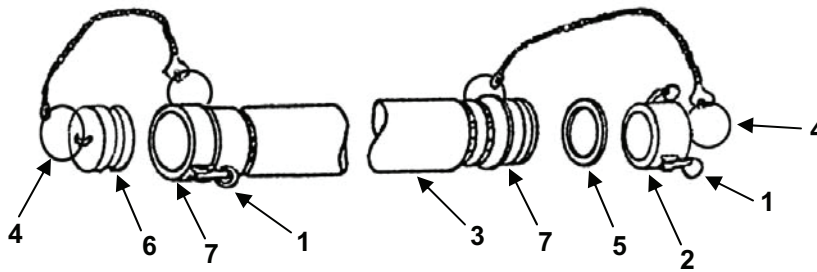

Figure 1. Hose Assembly.

Quick Disconnect Cap Gasket

1. Open quick disconnect (Figure 1, Item 1) and remove quick disconnect cap (Figure 1, Item 2) from hose (Figure 1, Item 3).
2. Remove and discard gasket (Figure 1, Item 5).

Quick Disconnect Plug

1. Open quick disconnect (Figure 1, Item 1) and remove quick disconnect plug (Figure 1, Item 6) from hose (Figure 1, Item 3).
2. Remove chain ring (Figure 1, Item 4) from quick disconnect plug (Figure 1, Item 6).

INSPECTION

1. Inspect hose (Figure 1, Item 3) for cuts, punctures and deterioration.
2. Inspect hose end fittings (Figure 1, Item 7) for damage.

REPAIR

Repair consists of replacing quick disconnect cap and plug.

INSTALLATION**Quick Disconnect Plug**

1. Install quick disconnect plug (Figure 1, Item 6) on hose (Figure 1, Item 3).
2. Lock quick disconnect (Figure 1, Item 1).
3. Install chain ring (Figure 1, Item 4) onto quick disconnect plug (Figure 1, Item 6).

Quick Disconnect Cap Gasket

1. Install new gasket (Figure 1, Item 5) into quick disconnect cap (Figure 1, Item 2).
2. Install quick disconnect cap (Figure 1, Item 2) on hose (Figure 1, Item 3).
3. Lock quick disconnect (Figure 1, Item 1).

Quick Disconnect Cap

1. Install quick disconnect cap (Figure 1, Item 2) on hose (Figure 1, Item 3).
2. Lock quick disconnect (Figure 1, Item 1).
3. Install chain ring (Figure 1, Item 4) on quick disconnect cap (Figure 1, Item 2).

END OF WORK PACKAGE

**FIELD MAINTENANCE
NOZZLE ASSEMBLY
INSPECT/ REPLACE**

INITIAL SETUP:**Tools:**

Tool Kit, General Mechanics (WP 0031, Item 1)

Materials/Parts:

Gasket (WP 0034, Item 5)

REMOVAL**NOTE**

Before removing any of these components, if attached to the hose assembly and the filler/discharge assembly, the gate valve must be shut off.

Quick Disconnect Plug

1. Open quick disconnect (Figure 1, Item 1) and remove quick disconnect plug (Figure 1, Item 2) from quick disconnect coupling half (Figure 1, Item 3).
2. Remove chain ring (Figure 1, Item 4) from quick disconnect coupling half (Figure 1, Item 3).

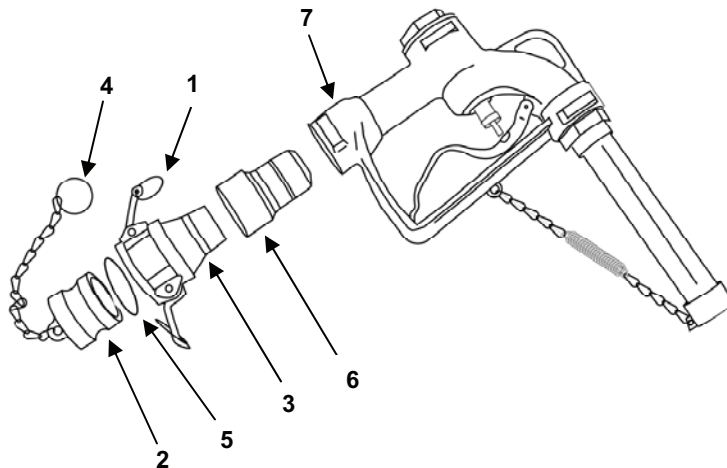

Figure 1. Nozzle Assembly.

Quick Disconnect Coupling Half Gasket

1. Open quick disconnect (Figure 1, Item 1) and remove quick disconnect plug (Figure 1, Item 2) from quick disconnect coupling half (Figure 1, Item 3).
2. Remove and discard gasket (Figure 1, Item 5).

Quick Disconnect Coupling Half

1. Open quick disconnect (Figure 1, Item 1) and remove quick disconnect plug (Figure 1, Item 2) from quick disconnect coupling half (Figure 1, Item 3).
2. Remove chain ring (Figure 1, Item 4) from quick disconnect coupling half (Figure 1, Item 3).
3. Unscrew and remove quick disconnect coupling half (Figure 1, Item 3) from pipe swing joint (Figure 1, Item 6) .

Pipe Swing Joint

1. Unscrew and remove from nozzle (Figure 1, Item 7) pipe swing joint (Figure 1, Item 6).
2. Unscrew pipe swing joint (Figure 1, Item 6) from quick disconnect coupling half (Figure 1, Item 3).

Nozzle

Unscrew and remove nozzle (Figure 1, Item 7) from pipe swing joint (Figure 1, Item 6).

INSPECTION

1. Inspect all components for gouges, nicks, dents that may cause leaking or improper fit.
2. Inspect nozzle (Figure 1, Item 7) for damage and proper operation.

REPAIR

Repair consists of replacing components.

INSTALLATION**Nozzle**

1. Screw nozzle (Figure 1, Item 7) onto pipe swing joint (Figure 1, Item 6).
2. Ensure nozzle (Figure 1, Item 7) will swivel.

Pipe Swing Joint

1. Screw pipe swing joint (Figure 1, Item 6) into quick disconnect coupling half (Figure 1, Item 3).
2. Screw nozzle (Figure 1, Item 7) onto pipe swing joint (Figure 1, Item 6).

Quick Disconnect Coupling Half

1. Screw quick disconnect coupling half (Figure 1, Item 3) into pipe swing joint (Figure 1, Item 6).
2. Position quick disconnect plug (Figure 1, Item 2) into quick disconnect coupling half (Figure 1, Item 3) and lock quick disconnect handles (Figure 1, Item 1).
3. Attach chain ring (Figure 1, Item 4) to quick disconnect coupling half (Figure 1, Item 3).

Quick Disconnect Coupling Half Gasket

1. Install new gasket (Figure 1, Item 5).
2. Position quick disconnect plug (Figure 1, Item 2) into quick disconnect coupling half (Figure 1, Item 3) and lock quick disconnect handles (Figure 1, Item 1).

Quick Disconnect Plug

1. Position quick disconnect plug (Figure 1, Item 2) into quick disconnect coupling half (Figure 1, Item 3) and lock quick disconnect handles (Figure 1, Item 1).
2. Attach chain ring (Figure 1, Item 4) to quick disconnect coupling half (Figure 1, Item 3).

END OF WORK PACKAGE

CHAPTER 6
PARTS INFORMATION
FOR
3K & 5K SEMI-TRAILER MOUNTED FABRIC TANK (SMFT), WATER

**FIELD MAINTENANCE
3K & 5K SEMI-TRAILER MOUNTED FABRIC TANK (SMFT), WATER
REPAIR PARTS AND SPECIAL TOOLS LIST (RPSTL) INTRODUCTION**

INTRODUCTION

SCOPE

This RPSTL lists and authorizes spares and repair parts; special tools; special test, measurement and diagnostic equipment (TMDE); and other special support equipment required for performance of field level maintenance of the SMFT. It authorizes the requisitioning, issue and disposition of spares, repair parts and special tools as indicated by the source, maintenance and recoverability (SMR) codes.

GENERAL

In addition to the Introduction work package, this RPSTL is divided into the following work packages.

1. Repair Parts List Work Packages. Work packages containing lists of spares and repair parts authorized by this RPSTL for use in the performance of maintenance. These work packages also include parts which must be removed for replacement of the authorized parts. Parts lists are composed of functional groups in ascending alphanumeric sequence, with the parts in each group listed in ascending figure and item number sequence. Sending units, brackets, filters and bolts are listed with the component they mount on. Bulk materials are listed by item name in FIG. BULK at the end of the work packages. Repair parts kits are listed at the end of the individual work packages. Repair parts for reparable special tools are also listed in a separate work package. Items listed are shown on the associated illustrations.
2. Special Tools List Work Packages. Work packages containing lists of special tools, special TMDE and special support equipment authorized by this RPSTL (as indicated by Basis of Issue (BOI) information in the DESCRIPTION AND USABLE ON CODE (UOC) column). Tools that are components of common tool sets and/or Class VII are not listed.
3. Cross-Reference Indexes Work Packages. There are two cross-reference indexes work packages in this RPSTL: the National Stock Number (NSN) Index work package and the Part Number (P/N) Index work package. The National Stock Number Index work package refers you to the figure and item number. The Part Number Index work package refers you to the figure and item number.

EXPLANATION OF COLUMNS IN THE REPAIR PARTS LIST AND SPECIAL TOOLS LIST WORK PACKAGES

ITEM NO. (Column (1)). Indicates the number used to identify items called out in the illustration.

SMR CODE (Column (2)). The SMR code containing supply/requisitioning information, maintenance level authorization criteria and disposition instruction, as shown in the following breakout. This entry may be subdivided into 4 subentries, one for each service.

TABLE 1. SMR Code Explanation.

Source Code <u>XX</u>	Maintenance Code <u>XX</u>	Recoverability Code <u>X</u>
1 st two positions: How to get an item.	3 rd position: Who can install, replace or use the item.	4 th position: Who can do complete repair* on the item.
		5 th position: Who determines disposition action on unserviceable items.

Source Code. The source code tells you how you get an item needed for maintenance, repair or overhaul of an end item/equipment. Explanations of source codes follow:

Source Code

Application/Explanation

PA
PB
PC
PD
PE
PF
PG
PH
PR
PZ

NOTE

Items coded PC are subject to deterioration.

Stock items; use the applicable NSN to requisition/request items with these source codes. They are authorized to the level indicated by the code entered in the third position of the SMR code.

Items with these codes are not to be requested/requisitioned individually. They are part of a kit which is authorized to the maintenance level indicated in the third position of the SMR code. The complete kit must be requisitioned and applied.

Items with these codes are not to be requisitioned/requested individually. They must be made from bulk material which is identified by the part number in the DESCRIPTION AND USABLE ON CODE (UOC) column and listed in the bulk material group work package of the RPSTL. If the item is authorized to you by the third position code of the SMR code, but the source code indicates it is made at higher level, order the item from the higher level of maintenance.

MF – Made at field
MH – Made at below depot/
sustainment level
ML – Made at SRA
MD – Made at Depot
MG – Navy only

*Complete Repair: Maintenance capacity, capability and authority to perform all corrective maintenance tasks of the "Repair" function in a use/user environment in order to restore serviceability to a failed item.

<u>Source Code</u>	<u>Application/Explanation</u>
AF - Assembled by field AH - Assembled by below depot sustainment level AL - Assembled by SRA AD - Assembled by depot AG - Navy only	Items with these codes are not to be requested/requisitioned individually. The parts that make up the assembled item must be requisitioned or fabricated and assembled at the level of maintenance indicated by the source code. If the third position of the SMR code authorizes you to replace the item, but the source code indicates the item is assembled at a higher level, order the item from the higher level of maintenance.
XA	Do not requisition an "XA" coded item. Order the next higher assembly. (Refer to the NOTE below.)
XB	If an item is not available from salvage, order it using the CAGEC and part number.
XC	Installation drawings, diagrams, instruction sheets, field service drawings; identified by manufacturer's part number.
XD	Item is not stocked. Order an XD-coded item through local purchase or normal supply channels using the CAGEC and part number given, if no NSN is available.

NOTE

Cannibalization or controlled exchange, when authorized, may be used as a source of supply for items with the above source codes except for those items source coded "XA" or those aircraft support items restricted by requirements of AR 750-1.

Maintenance Code. Maintenance codes tell you the level(s) of maintenance authorized to use and repair support items. The maintenance codes are entered in the third and fourth positions of the SMR code as follows:

Third Position. The maintenance code entered in the third position tells you the lowest maintenance level authorized to remove, replace and use an item. The maintenance code entered in the third position will indicate authorization to the following levels of maintenance:

<u>Maintenance Code</u>	<u>Application/Explanation</u>
F -	Field maintenance can remove, replace and use the item.
H -	Below Depot Sustainment maintenance can remove, replace and use the item.
L -	Specialized repair activity can remove, replace and use the item.
G -	Afloat and ashore intermediate maintenance can remove, replace and use the item (Navy only).
K -	Contractor facility can remove, replace and use the item.
Z -	Item is not authorized to be removed, replaced or used at any maintenance level.
D -	Depot can remove, replace and use the item.

*NOTE – Army may use C in the third position. However, for joint service publications, Army will use O.

Fourth Position. The maintenance code entered in the fourth position tells you whether or not the item is to be repaired and identifies the lowest maintenance level with the capability to do complete repair (perform all authorized repair functions).

NOTE

Some limited repair may be done on the item at a lower level of maintenance, if authorized by the Maintenance Allocation Chart (MAC) and SMR codes.

Maintenance

<u>Code</u>	<u>Application/Explanation</u>
F -	Field is the lowest level that can do complete repair of the item.
H -	Below Depot Sustainment is the lowest level that can do complete repair of the item.
L -	Specialized repair activity is the lowest level that can do complete repair of the item.
D -	Depot is the lowest level that can do complete repair of the item.
G -	Both afloat and ashore intermediate levels are capable of complete repair of item (Navy only).
K -	Complete repair is done at contractor facility.
Z -	Nonreparable. No repair is authorized.
B -	No repair is authorized. No parts or special tools are authorized for maintenance of "B" coded item. However, the item may be reconditioned by adjusting, lubricating, etc., at the user level.

Recoverability Code. Recoverability codes are assigned to items to indicate the disposition action on unserviceable items. The recoverability code is shown in the fifth position of the SMR code as follows:

Recoverability

<u>Code</u>	<u>Application/Explanation</u>
Z -	Nonreparable item. When unserviceable, condemn and dispose of the item at the level of maintenance shown in the third position of the SMR code.
F -	Reparable item. When uneconomically repairable, condemn and dispose of the item at the field level.
H -	Reparable item. When uneconomically repairable, condemn and dispose of the item at the below depot sustainment level.
D -	Reparable item. When beyond lower level repair capability, return to depot. Condemnation and disposal of items are not authorized below depot level.
L -	Reparable item. Condemnation and disposal not authorized below Specialized Repair Activity (SRA).
A -	Item requires special handling or condemnation procedures because of specific reasons (such as precious metal content, high dollar value, critical material or hazardous material). Refer to appropriate manuals/directives for specific instructions.
G -	Field level repairable item. Condemn and dispose at either afloat or ashore intermediate levels. (Navy only)
K -	Reparable item. Condemnation and disposal to be performed at contractor facility.

NSN (Column (3)). The NSN for the item is listed in this column.

CAGEC (Column (4)). The Commercial and Government Entity Code (CAGEC) is a five-digit code which is used to identify the manufacturer, distributor or Government agency/activity that supplies the item.

PART NUMBER (Column (5)). Indicates the primary number used by the manufacturer (individual, company, firm, corporation or Government activity), which controls the design and characteristics of the item by means of its engineering drawings, specifications, standards and inspection requirements to identify an item or range of items.

NOTE

When you use an NSN to requisition an item, the item you receive may have a different part number from the number listed.

DESCRIPTION AND USABLE ON CODE (UOC) (Column (6)). This column includes the following information:

1. The federal item name and, when required, a minimum description to identify the item.
2. Part numbers of bulk materials are referenced in this column in the line entry to be manufactured or fabricated.
3. Hardness Critical Item (HCI). A support item that provides equipment with special protection from the electromagnetic pulse (EMP) damage during a nuclear attack.
4. The statement END OF FIGURE appears just below the last item description in column (6) for a given figure in both the repair parts list and special tools list work packages.

QTY (Column (7)). The QTY (quantity per figure) column indicates the quantity of the item used in the breakout shown on the illustration/figure, which is prepared for a functional group, subfunctional group or an assembly. A "V" appearing in this column instead of a quantity indicates that the quantity is variable and quantity may change from application to application.

EXPLANATION OF CROSS-REFERENCE INDEXES WORK PACKAGES FORMAT AND COLUMNS

1. National Stock Number (NSN) Index Work Package. NSN's in this index are listed in National Item Identification Number (NIIN) sequence.

STOCK NUMBER Column. This column lists the NSN in NIIN sequence. The NIIN consists of the last nine digits of the NSN. When using this column to locate an item, ignore the first four digits of the NSN. However, the complete NSN should be used when ordering items by stock number. For example, if the NSN is 5385-01-574-1476, the NIIN is 01-574-1476.

FIG. Column. This column lists the number of the figure where the item is identified/located. The figures are in numerical order in the repair parts list and special tools list work packages.

ITEM Column. The item number identifies the item associated with the figure listed in the adjacent FIG. column. This item is also identified by the NSN listed on the same line.

2. Part Number (P/N) Index Work Package. Part numbers in this index are listed in ascending alphanumeric sequence (vertical arrangement of letter and number combinations which places the first letter or digit of each group in order A through Z, followed by the numbers 0 through 9 and each following letter or digit in like order).

PART NUMBER Column. Indicates the part number assigned to the item.

FIG. Column. This column lists the number of the figure where the item is identified/located in the repair parts list and special tools list work packages.

ITEM Column. The item number is the number assigned to the item as it appears in the figure referenced in the adjacent figure number column.

SPECIAL INFORMATION

UOC. The UOC appears in the lower left corner of the Description Column heading. Usable on codes are shown as "UOC:..." in the Description Column (justified left) on the first line under the applicable item/nomenclature. Uncoded items are applicable to all models. Identification of the UOCs used in the RPSTL are:

<u>Code</u>	<u>Used On</u>
NES	5K SMFT
TJS	3K SMFT

Fabrication Instructions. Bulk materials required to manufacture items are listed in the bulk material functional group of this RPSTL. Part numbers for bulk material are also referenced in the Description Column of the line item entry for the item to be manufactured/fabricated.

Index Numbers. Items which have the word BULK in the figure column will have an index number shown in the item number column. This index number is a cross-reference between the NSN/Part Number (P/N) Index work packages and the bulk material list in the repair parts list work package.

HOW TO LOCATE REPAIR PARTS

1. When NSNs or Part Numbers Are Not Known.

First. Using the table of contents, determine the assembly group to which the item belongs. This is necessary since figures are prepared for assembly groups and subassembly groups and lists are divided into the same groups.

Second. Find the figure covering the functional group or the subfunctional group to which the item belongs.

Third. Identify the item on the figure and note the number(s).

Fourth. Look in the repair parts list work packages for the figure and item numbers. The NSNs and part numbers are on the same line as the associated item numbers.

2. When NSN Is Known.

First. If you have the NSN, look in the STOCK NUMBER column of the NSN index work package. The NSN is arranged in NIIN sequence. Note the figure and item number next to the NSN.

Second. Turn to the figure and locate the item number. Verify that the item is the one you are looking for.

3. When Part Number Is Known.

First. If you have the part number and not the NSN, look in the PART NUMBER column of the part number index work package. Identify the figure and item number.

Second. Look up the item on the figure in the applicable repair parts list work package.

**FIELD MAINTENANCE
3K & 5K SEMI-TRAILER MOUNTED FABRIC TANK (SMFT), WATER
TANK FABRIC, COLLAPSIBLE**

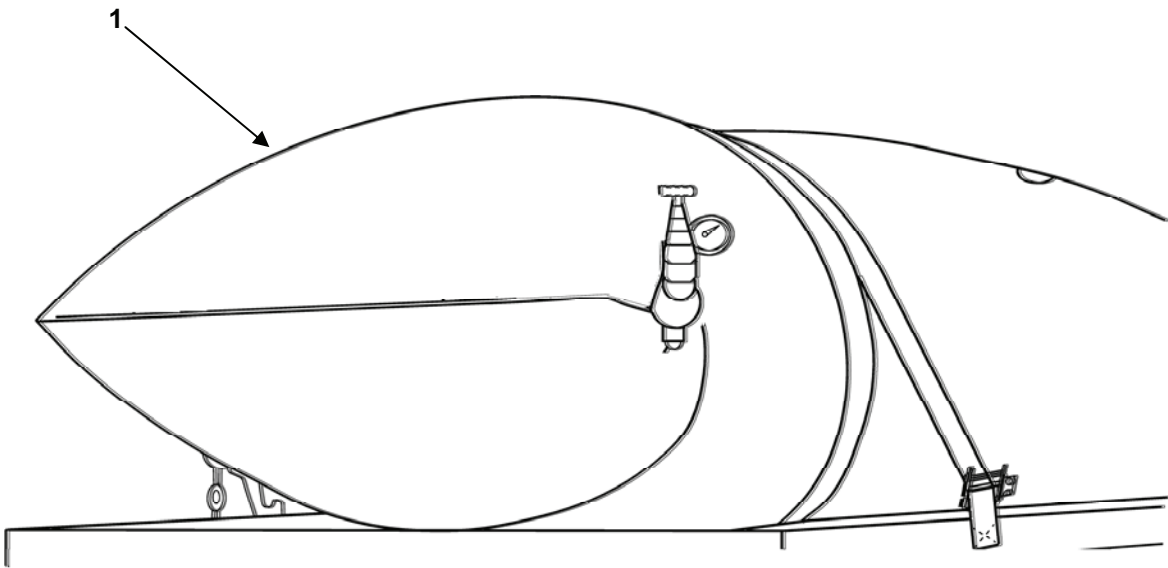

Figure 1. Tank Fabric, Collapsible.

(1) ITEM NO.	(2) SMR CODE	(3) NSN	(4) CAGEC	(5) PART NUMBER	(6) DESCRIPTION AND USABLE ON CODE (UOC)	(7) QTY
					GROUP 01 TANK, FABRIC, COLLAPSIBLE ASSEMBLY	
					FIG. 1. TANK, FABRIC, COLLAPSIBLE	
1	PAFFF	5430-01-564-7916	1YFX5	GTA-5K-SMFT	TANK, FABRIC, COLLAPSIBLE UOC: NES	1
1	PAFFF	5430-01-564-7919	1YFX5	GTA-3K-SMFT	TANK, FABRIC, COLLAPSIBLE UOC: TJS	1
END OF FIGURE						

FIELD MAINTENANCE
3K & 5K SEMI-TRAILER MOUNTED FABRIC TANK (SMFT), WATER
TANK ENVELOPE

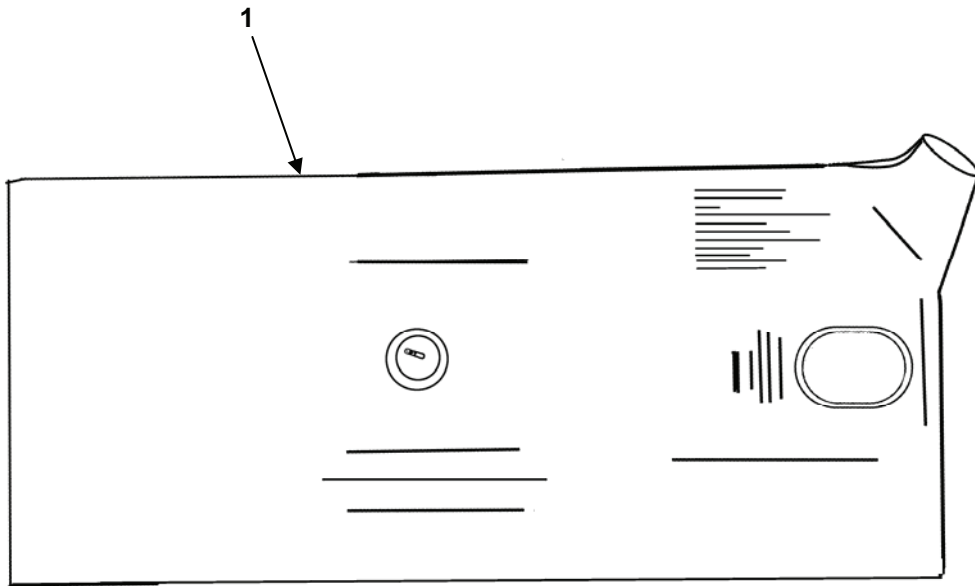

Figure 2. Tank Envelope.

(1) ITEM NO.	(2) SMR CODE	(3) NSN	(4) CAGEC	(5) PART NUMBER	(6) DESCRIPTION AND USABLE ON CODE (UOC)	(7) QTY
					GROUP 01 TANK, FABRIC, COLLAPSIBLE ASSEMBLY	
					FIG. 2. TANK ENVELOPE	
1	XAFFF		1YFX5	GTA-5K-SMFT- SHELL	TANK, COLLAPSIBLE UOC: NES	1
1	XAFFF		1YFX5	GTA-3K-SMFT- SHELL	TANK, COLLAPSIBLE UOC: TJS	1

END OF FIGURE

**FIELD MAINTENANCE
3K & 5K SEMI-TRAILER MOUNTED FABRIC TANK (SMFT), WATER
FILLER/DISCHARGE ASSEMBLY**

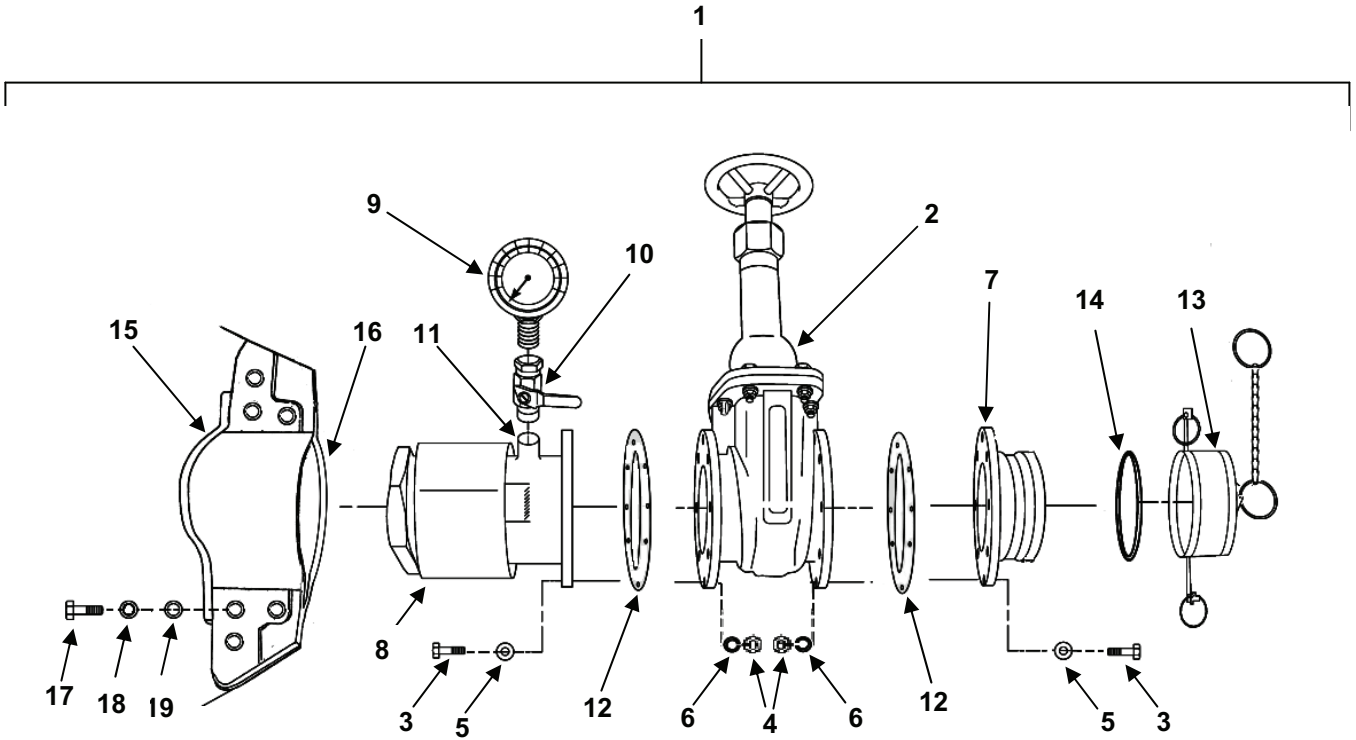

Figure 3. Filler/Discharge Assembly.

(1) ITEM NO.	(2) SMR CODE	(3) NSN	(4) CAGEC	(5) PART NUMBER	(6) DESCRIPTION AND USABLE ON CODE (UOC)	(7) QTY
					GROUP 02 FILLER/DISCHARGE ASSEMBLY	
					FIG. 3. FILLER/DISCHARGE ASSEMBLY	
1	XDFFF		1YFX5	GTA-4GATE-/SMFT	FILLER/DISCHARGE ASSY	1
2	PAFZZ	4820-01-189-2809	41592	235RF-0200 AV	.VALVE, GATE, 4 INCH	1
3	PAFZZ	5305-00-725-2317	80204	B1821BH038C150N	.SCREW, CAP, HEXAGON	16
4	PAFZZ	5310-00-732-0558	96906	MS51967-8	.NUT, PLAIN, HEXAGON	16
5	PAFZZ	5310-00-087-7493	96906	MS27183-13	.WASHER, FLAT	16
6	PAFZZ	5310-00-637-9541	81718	H2525M	.WASHER, LOCK	16
7	PAFZZ	4730-00-840-5347	58536	AA59326/4A-4-A-1	.COUPLING HALF, QUICK DISCONNECT	1
8	XDFZZ		1YFX5	GTA-4FCS	.FLANG CASTING, WITH SEAL	1
9	PAFZZ		4K739	DEW-LZ-10-25	.GAGE, PRESSURE 0-10 PSI	1
10	PAFZZ		56173	027-4F4M-B,SH,ENP	.ADAPTER, VALVE 1/4F X 1/4M NPT PSI	1
11	XDFZZ		1YFX5	GTA-PP1/4	.PLUG, PIPE 1/4 INCH NPT PSI	1
12	PAFZZ	5330-01-262-5120	05476	FCB-62398	. GASKET	2
13	PAFZZ	4730-00-640-6156	58536	AA59326IX-9	.CAP, QUICK DISCONNECT 4 INCH	1
14	PAFZZ	5330-00-899-4509	58536	AA59326-9	..GASKET	1
15	XDFZZ		1YFX5	GTA-4TC	.CLAMP TOP	1
16	XDFZZ		1YFX5	GTA-4BC	.CLAMP BOTTOM	1
17	PAFZZ	5305-01-516-6195	39428	91257A722	.SCREW, CAP, HEXAGON	6
18	PAFZZ	5310-01-454-3892	80204	ANSI B18.22.1	.WASHER, FLAT	6
19	PAFZZ	5330-01-525-8494	83259	600-0002-1/2	.PACKING, WITH RETAINER	6

END OF FIGURE

FIELD MAINTENANCE
3K & 5K SEMI-TRAILER MOUNTED FABRIC TANK (SMFT), WATER
INSPECTION PLATE

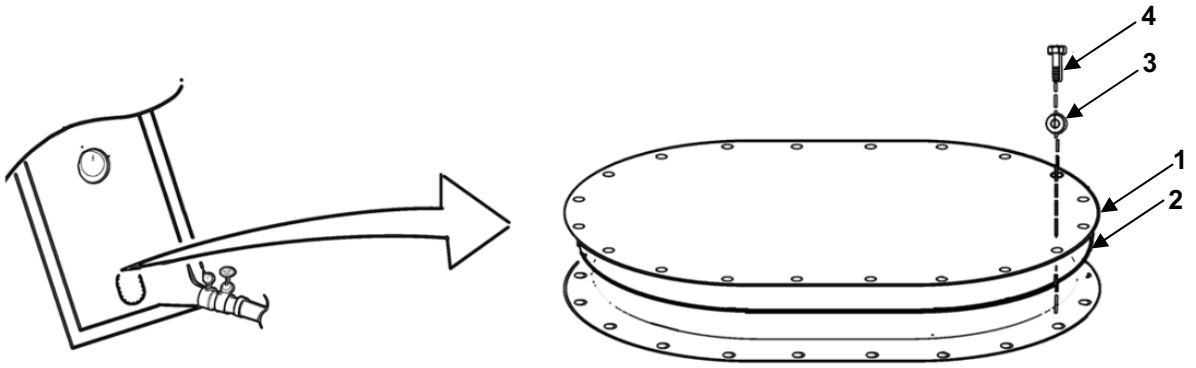

Figure 4. Inspection Plate.

(1) ITEM NO.	(2) SMR CODE	(3) NSN	(4) CAGEC	(5) PART NUMBER	(6) DESCRIPTION AND USABLE ON CODE (UOC)	(7) QTY
					GROUP 03 INSPECTION PLATE	
					FIG. 4. INSPECTION PLATE	
1	XDFZZ		63711	OCP-400S-AL	INSPECTION PLATE	1
2	PAFZZ	5331-00-364-9862	81343	AS3578-383	O-RING	1
3	PAFZZ	5310-00-809-4058	96906	MS27183-10	WASHER, FLAT	20
4	PAFZZ		39428	92865A541	CAP SCREW, HEXAGON	20
					END OF FIGURE	

FIELD MAINTENANCE
3K & 5K SEMI-TRAILER MOUNTED FABRIC TANK (SMFT), WATER
RELIEF VALVE

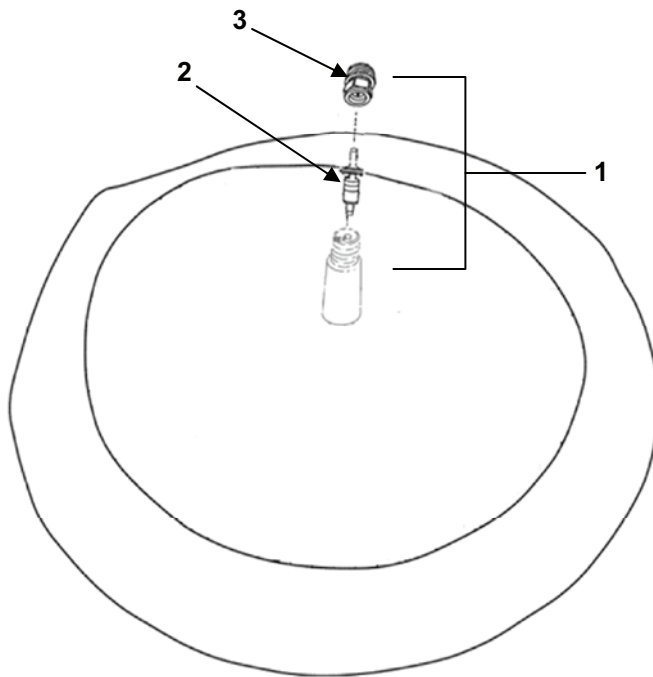

Figure 5. Relief Valve.

(1) ITEM NO.	(2) SMR CODE	(3) NSN	(4) CAGEC	(5) PART NUMBER	(6) DESCRIPTION AND USABLE ON CODE (UOC)	(7) QTY
					GROUP 04 RELIEF VALVE	
					FIG. 5. RELIEF VALVE	
1	XAFZZ		1YX50	NTH90156	VALVE, RELIEF AIR BLEED	1
2	PAFZZ		1YX50	NTH90100	VALVE CORE	1
3	PAFZZ		1YX50	NTH90180	CAP, VALVE	1
					END OF FIGURE	

FIELD MAINTENANCE
3K & 5K SEMI-TRAILER MOUNTED FABRIC TANK (SMFT), WATER
HOSE ASSEMBLY FOUR INCH

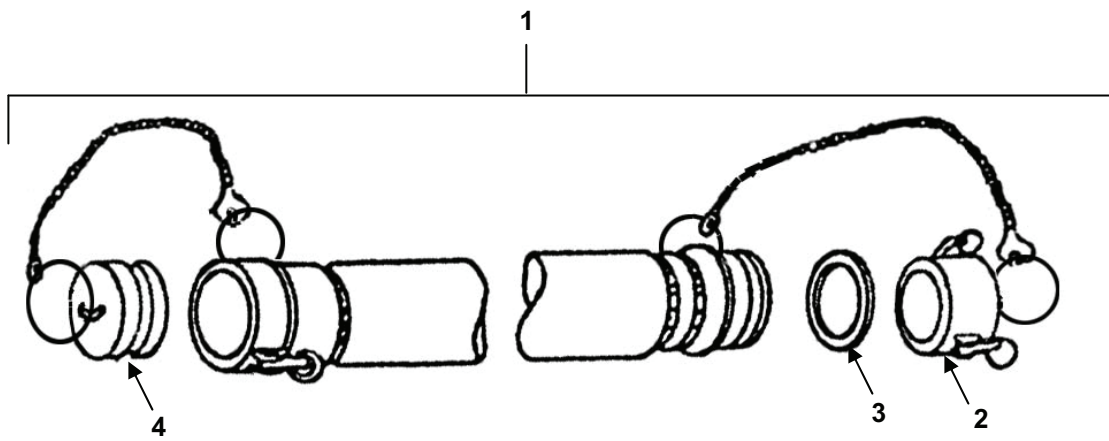

Figure 6. Hose Assembly, Four Inch.

(1) ITEM NO.	(2) SMR CODE	(3) NSN	(4) CAGEC	(5) PART NUMBER	(6) DESCRIPTION AND USABLE ON CODE (UOC)	(7) QTY
					GROUP 05 HOSE ASSEMBLY, FOUR INCH	
					FIG. 6. HOSE ASSEMBLY, 4 INCH	
1	PAFFF		1YFX5	GTA-WHA-4X10	HOSE ASSEMBLY, 4 INCH HOSE, 10 FEET LONG, MALE X FEMALE	2
2	PAFZZ	4730-00-640-6156	58536	AA59326IX-9	.CAP, QUICK DISCONNECT 4 INCH	1
3	PAFZZ	5330-00-899-4509	58536	AA59326-9	..GASKET	1
4	PAFZZ	4730-00-640-6188	58536	AA59326X19	.PLUG, QUICK DISCONNECT 4 INCH	1
					END OF FIGURE	

FIELD MAINTENANCE
3K & 5K SEMI-TRAILER MOUNTED FABRIC TANK (SMFT), WATER
HOSE ASSEMBLY, TWO INCH

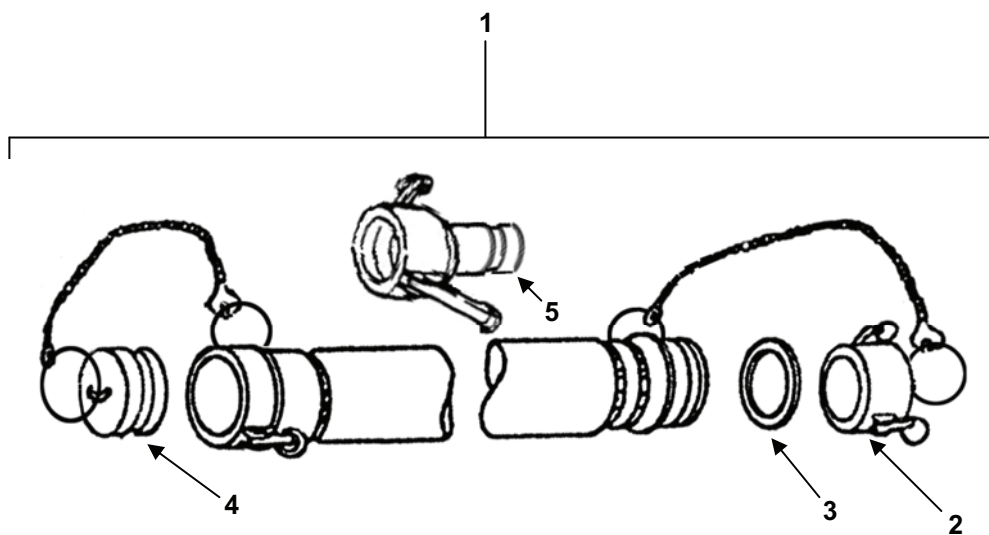

Figure 7. Hose Assembly with Reducer, Two Inch

(1) ITEM NO.	(2) SMR CODE	(3) NSN	(4) CAGEC	(5) PART NUMBER	(6) DESCRIPTION AND USABLE ON CODE (UOC)	(7) QTY
					GROUP 05 HOSE ASSEMBLY, TWO INCH	
					FIG. 7. HOSE ASSEMBLY, TWO INCH	
1	PAFZZ		1YFX5	GTA-WHA-2X10	HOSE ASSEMBLY, QC WITH DUST CAP AND PLUG UOC: TJS	2
2	PAFZZ	4730-00-649-9100	58536	AA59326IX16	.CAP, QUICK DISCONNECT 2 INCH UOC: TJS	1
3	PAFZZ	5330-00-612-2414	58536	AA59326-G6	..GASKET UOC: TJS	1
4	PAFZZ	4730-00-915-5127	58536	AA59326X16	.PLUG, QUICK DISCONNECT 2 INCH UOC: TJS	1
5	PAFZZ	4730-00-887-3822	0U9Z1	633BA-4X2AL	REDUCER, QUICK DISCONNECT UOC: TJS	1

END OF FIGURE

FIELD MAINTENANCE
3K & 5K SEMI-TRAILER MOUNTED FABRIC TANK (SMFT), WATER
NOZZLE ASSEMBLY

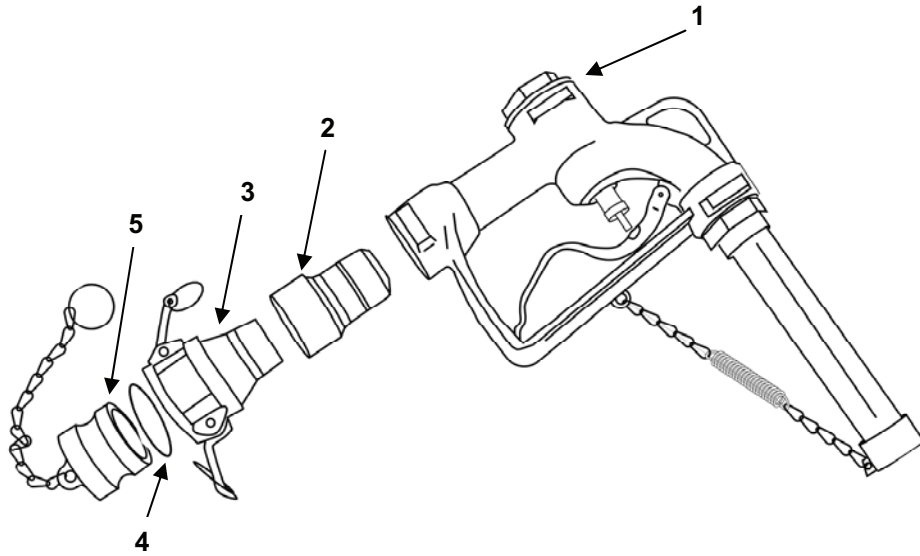

Figure 8. Nozzle Assembly.

(1) ITEM NO.	(2) SMR CODE	(3) NSN	(4) CAGEC	(5) PART NUMBER	(6) DESCRIPTION AND USABLE ON CODE (UOC)	(7) QTY
					GROUP 06 NOZZLE ASSEMBLY	
					FIG. 8. NOZZLE ASSEMBLY	
1	PAFZZ	2910-01-188-8198	81718	190-GW-5115 1- 1/2IN	NOZZLE, WATER DISTRIBUTION UOC: TJS	1 1
2	PAFZZ	4730-01-109-0790	41592	122WA-0300 1S	SWING JOINT, PIPE UOC: TJS	1
3	PAFZZ	4730-01-192-1624	96906	MS49002-9	COUPLING HALF, QUICK DISCONNECT UOC: TJS	1
4	PAFZZ	5330-00-612-2414	58536	AA59326-G6	GASKET UOC: NES	1
5	PAFZZ	4730-00-915-5127	58536	AA59326X16	PLUG, QUICK DISCONNECT 2 INCH UOC: TJS	1

END OF FIGURE

**FIELD MAINTENANCE
3K & 5K SEMI-TRAILER MOUNTED FABRIC TANK (SMFT), WATER
NATIONAL STOCK NUMBER INDEX**

STOCK NUMBER	FIG.	ITEM
5310-00-087-7493	2	5
5331-00-364-9862	4	2
5330-00-612-2414	7	3
	8	5
5310-00-637-9541	2	6
4730-00-640-6156	2	13
	6	2
4730-00-640-6188	6	4
4730-00-649-9100	7	2
5305-00-725-2317	2	3
5310-00-732-0558	2	4
5310-00-809-4058	4	3
4730-00-840-5347	2	7
4730-00-887-3822	7	5
5330-00-899-4509	2	14
	6	3
4730-00-915-5127	7	4
	8	4
4730-01-109-0790	8	2
2910-01-188-8198	8	1
4820-01-189-2809	2	2
4730-01-192-1624	8	3
5330-01-262-5120	2	12
5310-01-422-4479	2	18
5305-01-516-6195	2	17
5330-01-525-8494	3	19
5430-01-564-7916	1	1
5430-01-564-7919	1	1

FIELD MAINTENANCE
 3K & 5K SEMI-TRAILER MOUNTED FABRIC TANK (SMFT), WATER
 PART NUMBER INDEX

PART NUMBER	FIG.	ITEM	PART NUMBER	FIG.	ITEM
AA59326IX16	7	2	NTH90100	5	2
AA59326X16	7	4	NTH90156	5	1
	8	5	NTH90180	5	3
AA59326X19	6	4	OCP-400S-AL	4	1
AA59326IX-9	3	13	027-4F4M-B,SH,ENP	3	10
	6	2	122WA-0300 1S	8	2
AA59326-G6	7	3	190-GW-5115 1-1/2IN	8	1
	8	4	235RF-0200 AV	3	2
AA59326-9	3	14	600-0002-1/2	3	19
	6	3	633BA-4X2AL	7	5
AA59326/4A-4-A-1	3	7	92865A541	4	4
ANSI B18.22.1	3	18	91257A722	3	17
AS3578-383	4	2			
B1821BH038C150N	3	3			
DEW-LZ-10-25	3	9			
FCB-62398	3	12			
GTA-PP1/4	3	11			
GTA-WHA-2X10	7	1			
GTA-WHA-4X10	6	1			
GTA-3K-SMFT	1	1			
GTA-3K-SMFT-SHELL	2	1			
GTA-4FCS	3	8			
GTA-4GATE-/SMFT	3	1			
GTA-4BC	3	16			
GTA-4TC	3	15			
GTA-5K-SMFT	1	1			
GTA-5K-SMFT-SHELL	2	1			
H2525M	3	6			
MS1967-8	3	4			
MS27183-10	4	3			
MS27183-13	3	5			
MS49002-9	8	3			

CHAPTER 7

SUPPORTING INFORMATION

FOR

3K & 5K SEMI-TRAILER MOUNTED FABRIC TANK (SMFT), WATER

**OPERATOR AND FIELD MAINTENANCE
3K & 5K SEMI-TRAILER MOUNTED FABRIC TANK (SMFT), WATER
REFERENCES**

SCOPE

This work package lists all forms, pamphlets, field manuals, technical manuals and miscellaneous publications referenced in this manual. Also listed are publications that should be consulted for additional information.

FORMS

DA Form 2028	Recommended Changes to Publications and Blank Forms
SF 361	Transportation Discrepancy Report
SF 368	Product Quality Deficiency Report

PAMPHLETS

DA PAM 738-750	Functional User's Manual for the Army Maintenance Management System (TAMMS)
DA PAM 738-751	Functional User's Manual for the Army Maintenance Management System-Aviation (TAMMS-A)
DA PAM 750-8	The Army Maintenance Management System (TAMMS) User's Manual

FIELD MANUALS

FM 3-3	Chemical and Biological Contamination Avoidance
FM 3-4	NBC Protection
FM 3-5	NBC Decontamination
FM 4-25.11	First Aid

TECHNICAL MANUALS

TM 740-90-1	Administrative Storage Requirements
TM 750-244-3	Procedures for Destruction of Equipment to Prevent Enemy Use

REGULATIONS

AR 700-138	Army Logistics Readiness and Sustainability
AR 750-1	Army Materiel Maintenance Policy and Retail Maintenance Operations

MISCELLANEOUS

CTA 8-100	Army Medical Department Expendable/Durable Items
CTA 50-909	Field and Garrison Furnishings and Equipment
CTA 50-970	Expendable/Durable Items (Except Medical, Class V, Repair Parts and Heraldic Items)

**FIELD MAINTENANCE
3K & 5K SEMI-TRAILER MOUNTED FABRIC TANK (SMFT), WATER
MAINTENANCE ALLOCATION CHART (MAC) INTRODUCTION**

INTRODUCTION

The Army Maintenance System MAC

This introduction provides a general explanation of all maintenance and repair functions authorized at the two maintenance levels under the Two-Level Maintenance System concept.

The MAC (immediately following the introduction) designates overall authority and responsibility for the performance of maintenance functions on the identified end item or component. The application of the maintenance functions to the end item or component shall be consistent with the capacities and capabilities of the designated maintenance levels, which are shown on the MAC in column (4) as:

Field - includes two subcolumns, Crew (C) and Maintainer (F).

Sustainment - includes two subcolumns, Below Depot (H) and Depot (D).

The maintenance to be performed at field and sustainment levels is described as follows:

1. Crew maintenance. The responsibility of a using organization to perform maintenance on its assigned equipment. It normally consists of inspecting, servicing, lubricating, adjusting, and replacing parts, minor assemblies, and subassemblies. The replace function for this level of maintenance is indicated by the letter "C" in the third position of the SMR code. A "C" appearing in the fourth position of the SMR code indicates complete repair is possible at the crew maintenance level.
2. Maintainer maintenance. Maintenance accomplished on a component, accessory, assembly, subassembly, plug-in unit, or other portion either on the system or after it is removed. The replace function for this level of maintenance is indicated by the letter "F" appearing in the third position of the SMR code. An "F" appearing in the fourth position of the SMR code indicates complete repair is possible at the field maintenance level. Items are returned to the user after maintenance is performed at this level.
3. Below depot sustainment. Maintenance accomplished on a component, accessory, assembly, subassembly, plug-in unit, or other portion either on the system or after it is removed. The replace function for this level of maintenance is indicated by the letter "H" appearing in the third position of the SMR code. An "H" appearing in the fourth position of the SMR code indicates complete repair is possible at the below depot sustainment maintenance level. Items are returned to the supply system after maintenance is performed at this level.
4. Depot sustainment. Maintenance accomplished on a component, accessory, assembly, subassembly, plug-in unit, or other portion either on the system or after it is removed. The replace function for this level of maintenance is indicated by the letter "D" or "K" appearing in the third position of the SMR code. Depot sustainment maintenance can be performed by either depot personnel or contractor personnel. A "D" or "K" appearing in the fourth position of the SMR code indicates complete repair is possible at the depot sustainment maintenance level. Items are returned to the supply systems after maintenance is performed at this level.

The tools and test equipment requirements table (immediately following the MAC) lists the tools and test equipment (both special tools and common tool sets) required for each maintenance function as referenced from the MAC.

The remarks table (immediately following the tools and test equipment requirements) contains supplemental instructions and explanatory notes for a particular maintenance function.

Maintenance Functions

Maintenance functions are limited to and defined as follows.

1. **Inspect.** To determine the serviceability of an item by comparing its physical, mechanical and/or electrical characteristics with established standards through examination (e.g., by sight, sound or feel). This includes scheduled inspections and gauging and evaluation of cannon tubes.
2. **Test.** To verify serviceability by measuring the mechanical, pneumatic, hydraulic or electrical characteristics of an item and comparing those characteristics with prescribed standards on a scheduled basis, i.e., load testing of lift devices and hydrostatic testing of pressure hoses.
3. **Service.** Operations required periodically to keep an item in proper operating condition; e.g., to clean (includes decontaminate, when required), to preserve, to drain, to paint, or to replenish fuel, lubricants, chemical fluids or gases. This includes scheduled exercising and purging of recoil mechanisms. The following are examples of service functions:
 - a. **Unpack.** To remove from packing box for service or when required for the performance of maintenance operations.
 - b. **Repack.** To return item to packing box after service and other maintenance operations.
 - c. **Clean.** To rid the item of contamination.
 - d. **Touch up.** To spot paint scratched or blistered surfaces.
 - e. **Mark.** To restore obliterated identification.
4. **Adjust.** To maintain or regulate, within prescribed limits, by bringing into proper position, or by setting the operating characteristics to specified parameters.
5. **Align.** To adjust specified variable elements of an item to bring about optimum or desired performance.
6. **Calibrate.** To determine and cause corrections to be made or to be adjusted on instruments of test, measuring and diagnostic equipment used in precision measurement. Consists of comparisons of two instruments, one of which is a certified standard of known accuracy, to detect and adjust any discrepancy in the accuracy of the instrument being compared.
7. **Remove/Install.** To remove and install the same item when required to perform service or other maintenance functions. Install may be the act of emplacing, seating or fixing into position a spare, repair part or module (component or assembly) in a manner to allow the proper functioning of equipment or a system.
8. **Paint (ammunition only).** To prepare and spray color coats of paint so that the ammunition can be identified and protected. The color indicating primary use is applied, preferably, to the entire exterior surface as the background color of the item. Other markings are to be repainted as original so as to retain proper ammunition identification.
9. **Replace.** To remove an unserviceable item and install a serviceable counterpart in its place. "Replace" is authorized by the MAC and assigned maintenance level is shown as the third position code of the Source, Maintenance, and Recoverability (SMR) code.
10. **Repair.** The application of maintenance services including fault location/troubleshooting, removal/installation, disassembly/assembly procedures and maintenance actions to identify troubles and restore serviceability to an item by correcting specific damage, fault, malfunction or failure in a part, subassembly, module (component or assembly), end item or system.

NOTE

The following definitions are applicable to the “repair” maintenance function.

Services. Inspect, test, service, adjust, align, calibrate and/or replace.

Fault location/troubleshooting. The process of investigating and detecting the cause of equipment malfunctioning; the act of isolating a fault within a system or Unit Under Test (UUT).

Disassembly/assembly. The step-by-step breakdown (taking apart) of a spare/functional group coded item to the level of its least component that is assigned an SMR code for the level of maintenance under consideration (i.e., identified as maintenance significant).

Actions. Welding, grinding, riveting, straightening, facing, machining, and/or resurfacing.

11. Overhaul. That maintenance effort (service/action) prescribed to restore an item to a completely serviceable/operational condition as required by maintenance standards in appropriate technical publications. Overhaul is normally the highest degree of maintenance performed by the Army. Overhaul does not normally return an item to like new condition.
12. Rebuild. Consists of those services/actions necessary for the restoration of unserviceable equipment to a like new condition in accordance with original manufacturing standards. Rebuild is the highest degree of materiel maintenance applied to Army equipment. The rebuild operation includes the act of returning to zero those age measurements (e.g., hours/miles) considered in classifying Army equipment/components.

Explanation of Columns in the MAC

Column (1) — Group Number. Column (1) lists Functional Group Code (FGC) numbers, the purpose of which is to identify maintenance significant components, assemblies, subassemblies, and modules with the Next Higher Assembly (NHA).

Column (2) — Component/Assembly. Column (2) contains the item names of components, assemblies, subassemblies, and modules for which maintenance is authorized.

Column (3) — Maintenance Function. Column (3) lists the functions to be performed on the item listed in column (2). (For detailed explanation of these functions, refer to “Maintenance Functions” previously outlined.)

Column (4) — Maintenance Level. Column (4) specifies each level of maintenance authorized to perform each function listed in column (3) by indicating work time required (expressed as man-hours in whole hours or decimals) in the appropriate subcolumn. This work time figure represents the active time required to perform that maintenance function at the indicated level of maintenance. If the number or complexity of the tasks within the listed maintenance function varies at different maintenance levels, appropriate work time figures are to be shown for each level. The work time figure represents the average time required to restore an item (assembly, subassembly, component, module, end item, or system) to a serviceable condition under typical field operating conditions. This time includes preparation time (including any necessary disassembly/assembly time), troubleshooting/fault location time, and quality assurance time in addition to the time required to perform the specific tasks identified for the maintenance functions authorized in the MAC. The symbol designations for the various maintenance levels are as follows:

Field:

- C Crew maintenance
- F Maintainer maintenance

Sustainment:

- L Specialized Repair Activity (SRA)
- H Below depot maintenance
- D Depot maintenance

NOTE

The "L" maintenance level is not included in column (4) of the MAC. Functions to this level of maintenance are identified by a work time figure in the "H" column of column (4) and an associated reference code is used in the REMARKS column (6). This code is keyed to the remarks and the SRA complete repair application is explained there.

Column (5) — Tools and Equipment Reference Code. Column (5) specifies, by code, those common tool sets (not individual tools), common Test, Measurement, and Diagnostic Equipment (TMDE), and special tools, special TMDE, and special support equipment required to perform the designated function. Codes are keyed to the entries in the tools and test equipment table.

Column (6) — Remarks Code. When applicable, this column contains a letter code, in alphabetical order, which is keyed to the remarks table entries.

Explanation of Columns in the Tools and Test Equipment Requirements

Column (1) — Tool or Test Equipment Reference Code. The tool or test equipment reference code correlates with a code used in column (5) of the MAC.

Column (2) — Maintenance Level. The lowest level of maintenance authorized to use the tool or test equipment.

Column (3) — Nomenclature. Name or identification of the tool or test equipment.

Column (4) — National Stock Number (NSN). The NSN of the tool or test equipment.

Column (5) — Tool Number. The manufacturer's part number.

Explanation of Columns in the Remarks

Column (1) — Remarks Code. The code recorded in column (6) of the MAC.

Column (2) — Remarks. This column lists information pertinent to the maintenance function being performed as indicated in the MAC.

**FIELD MAINTENANCE
3K & 5K SEMI-TRAILER MOUNTED FABRIC TANK (SMFT), WATER
MAINTENANCE ALLOCATION CHART (MAC)**

Table 1. MAC for 3K & 5K Semi-Trailer Mounted Fabric Tank (SMFT), Water

(1) GROUP NUMBER	(2) COMPONENT/ ASSEMBLY	(3) MAINTENANCE FUNCTION	(4) MAINTENANCE LEVEL				(5) TOOLS AND EQUIPMENT REFERENCE CODE	(6) REMARKS CODE
			FIELD		SUSTAINMENT			
			CREW	MAINTAINER	BELOW DEPOT	DEPOT		
			C	F	H	D		
00	3K/5K SMFT Tank Assemblies							
01	Tank, Fabric Collapsible	Inspect Replace Repair Test	0.3	0.4 5.0 4.0		1,3 2	A,B	
02	Filler/Discharge Assembly	Inspect Replace Repair	0.1	0.4 0.5		1,4	A	
03	Inspection Plate	Inspect Replace	0.1	0.5		1,4	A	
04	Relief Valve	Inspect Replace	0.1	0.4			A	
05	Hose Assemblies	Inspect Replace Repair	0.1	0.4 0.5			A	
06	Nozzle Assembly	Inspect Replace	0.1	0.4			A	

Table 2. Tools and Test Equipment for SMFT, Water.

Tool or Test Equipment Ref. Code	Maintenance Level	Nomenclature	National Stock Number (NSN)	Tool Number
1	F	Tool Kit, General Mechanic's	5180-00-177-7033	SC-5180-90-CL-N26
2	F	Pneumatic Tire Valve Repair Tool	5120-00-308-3809	3522
3	C	Repair Kit	TBD	ATPD-2263 Type II
4	F	Torque Wrench	5120-00-554-7292	GGG-W-00686

Table 3. Remarks for SMFT, Water.

Remarks Code	Remarks
A	Repair or replacing defective parts.
B	Temporary repair using Repair Kit (WP 0011).

OPERATOR AND FIELD MAINTENANCE
3K & 5K SEMI-TRAILER MOUNTED FABRIC TANK (SMFT), WATER
COMPONENTS OF END ITEM (COEI) AND BASIC ISSUE ITEMS (BII) LISTS

INTRODUCTION**SCOPE**

This work package lists COEI and BII for the 3K and 5K SMFT Water Tanks to help you inventory items for safe and efficient operation of the equipment.

GENERAL

The COEI and BII information is divided into the following lists:

Components of End Item (COEI). This list is for information purposes only and is not authority to requisition replacements. These items are part of the 3K and 5K SMFT Water Tanks. As part of the end item, these items must be with the end item whenever it is issued or transferred between property accounts. Items of COEI are removed and separately packaged for transportation or shipment only when necessary. Illustrations are furnished to help you find and identify the items.

Basic Issue Items (BII). These essential items are required to place the 3K and 5K SMFT Water Tanks in operation, operate it, and to do emergency repairs. Although shipped separately packaged, BII must be with the 3K and 5K SMFT during operation and when it is transferred between property accounts. Listing these items is your authority to request/requisition them for replacement based on authorization of the end item by the TOE/MTOE. Illustrations are furnished to help you find and identify the items.

EXPLANATION OF COLUMNS IN THE COEI LIST AND BII LIST

Column (1) – Item Number. Gives you the reference number of the item listed.

Column (2) – National Stock Number (NSN) and Illustration. Identifies the stock number of the item to be used for requisitioning purposes and provides an illustration of the item.

Column (3) – Description, Part Number/(CAGEC). Identifies the Federal item name (in all capital letters) followed by a minimum description when needed. The stowage location of COEI and BII is also included in this column. The last line below the description is the part number and the Commercial and Government Entity Code (CAGEC) (in parentheses).

Column (4) – Usable On Code. When applicable, gives you a code if the item you need is not the same for different models of equipment. These codes are identified below:

<u>Code</u>	<u>Used On</u>
TJS	3K SMFT
NES	5K SMFT

Column (5) – U/I. Unit of Issue (U/I) indicates the physical measurement or count of the item as issued per the National Stock Number shown in the column (2).

Column (6) – Qty Rqr. Indicates the quantity required.

Table 1. Components of End Item List



(1) Item Number	(2) National Stock Number (NSN) and Illustration	(3) Description, Part Number/(CAGEC)	(4) Usable On Code	(5) U/I	(6) Qty Rqr
1	TBD 	FILLER/DISCHARGE ASSEMBLY GTA-4GATE-/SMFT (1YFX5)		EA	1
2	TBD 	INSPECTION PLATE OCP-400S-AL (63711)		EA	1
3	TBD 	NOZZLE ASSEMBLY 190-GW-5115 1-1/2 IN (81718)	TJS	EA	1
4	TBD 	SUCTION HOSE ASSEMBLY 2 in. X 10 ft. GTA-WHA-2X10 (1YFX5)	TJS	EA	2
5	TBD 	SUCTION HOSE ASSEMBLY, 4 in. X 10 ft. GTA-WHA-4X10 (1YFX5)		EA	2

Table 2. Basic Issue Items List





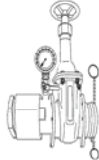
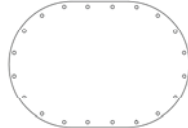
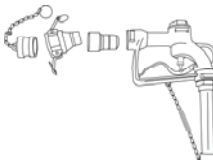

(1) Item Number	(2) National Stock Number (NSN) and Illustration	(3) Description, Part Number/(CAGEC)	(4) Usable On Code	(5) U/I	(6) Qty Rqr
1	TBD 	GROUND CLOTH WITH LIFTING HANDLES, Weather Resistant, 29 X 7ft 4 in., with Carry Sling. GTA-3KSMFT-GC (1YFX5)	TJS	EA	1
2	TBD 	GROUND CLOTH WITH LIFTING HANDLES, Weather Resistant, 40 X 7ft 4 in., with Carry Sling. GTA-5KSMFT-GC (1YFX5)	NES	EA	1
3		OPERATOR AND FIELD LEVEL MAINTENANCE MANUAL With Repair Parts and Special Tools List for 3K & 5K Semi-Trailer Mounted Fabric Tank (SMFT) Tank TM 10-5430-256-13&P		EA	1
4	TDB 	REPAIR KIT, Type II ATPD-2263 Type II (84583) Items 5 thru 13 make up the repair kit:		EA	1
5		CONTAINER ADTPD-2263 TYPE II CONTAINER CNT2 (84583)		EA	1
6	5342-00-720-8864 	PATCH ASSEMBLY 3 in., Mechanical 13202E2870-1(81349)		EA	2

Table 2. Basic Issue Items List (cont.)











(1) Item Number	(2) National Stock Number (NSN) and Illustration	(3) Description, Part Number/(CAGEC)	(4) Usable On Code	(5) U/I	(6) Qty Rqr
7	5430-00-720-8863 	PATCH ASSEMBLY 5 in., Mechanical 13202E2870-2 (81349)		EA	2
8	5430-00-720-8858 	PATCH ASSEMBLY 7.5 in., Mechanical 13202E2870-2 (81349)		EA	2
9	5510-01-115-0893 	PLUG, Wood, 5/8 In. 5-14-679-1-8 (84583)		EA	2
10	5510-01-412-0264 	PLUG, Wood, 1-1/2 In. M52255FIG3-1 1/2 (84583)		EA	2
11	5510-01-119-5995 	PLUG, Wood, 2 In. M52255FIG3-2 (84583)		EA	2

Table 2. Basic Issue Items List (cont.)

(1) Item Number	(2) National Stock Number (NSN) and Illustration	(3) Description, Part Number/(CAGEC)	(4) Usable On Code	(5) U/I	(6) Qty Rqr
12	5110-00-892-5071 	KNIFE, CRAFTSMAN'S PD5110-00-892-5071 (84583)		EA	1
13	TBD 	SHEET, Technical INS2 (84583)		EA	1
14	TBD 	TIE DOWN with SLEEVE, 4 inch x 30 ft , 20,000 lb Load Limit GTA-4X30-2X10SLEEVE (1YFX5)		EA	9
15	TBD 	WINCH GTA-SPW (1YFX5)		EA	18
16	TBD 	WINCH BAR 42313-10 (0VU83)		EA	1
17	TBD 	PAD 34 x 90 inches GTA-34-90-4PAD (1YFX5)		EA	4

**OPERATOR AND FIELD MAINTENANCE
3K & 5K SEMI-TRAILER MOUNTED FABRIC TANK (SMFT), WATER
EXPENDABLE AND DURABLE ITEMS LIST**

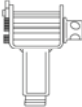
INTRODUCTION

Scope

This work package lists expendable and durable items that you will need to operate and maintain the 3K and 5K SMFT Water Tanks. This list is for information only and is not authority to requisition the listed items. These items are authorized to you by CTA 50-790, Expendable/Durable Items (Except Medical, Class V Repair Parts, and Heraldic items), CTA 50-909, Field and Garrison Furnishings and Equipment or CTA 8-100, Army Medical Department Expendable/Durable Items.

Explanation of Columns in the Expendable/Durable Items List

Column (1) - Item No. This number is assigned to the entry in the listing and is referenced in the narrative instructions to identify the item (e.g., "Use anti-seize compound (WP 0036, item 5)).

Column (2) - Level. This column identifies the lowest level of maintenance that requires the listed item (C = Crew, F = Maintainer).

Column (3) - National Stock Number (NSN). This is the NSN assigned to the item, which you can use to requisition it.

Column (4) - Item Name, Description, Part Number/(CAGEC). This column provides the other information you need to identify the item. The last line below the description is the part number and the Commercial and Government Entity Code (CAGEC) (in parentheses).

Column (5) - U/I. Unit of Issue (U/I) code shows the physical measurement or count of an item, such as gallon, dozen, gross, etc.

Table 1. Expendable and Durable Items List

(1) Item No.	(2) Level	(3) National Stock Number (NSN)	(4) Item Name, Description, Part Number/(CAGEC)	(5) U/I
1	C	6850-01-170-4434	Bleach, Laundry, Organic Chlorine 110470 (73042)	GL
2	C	7920-01-263-7624	Brush, Scrub 7451T14 (39428)	EA
3	C	8030-01-325-7551	Compound, Sealing PL32 L25 HYLOMAR (80244)	GL
4	C	7930-00-515-2477	Detergent, General Purpose Non-Toxic, Non-Hazardous 7930-00-515-2477 (80244)	BE

Table 1. Expendable and Durable Items List (Cont)

(1) Item No.	(2) Level	(3) National Stock Number (NSN)	(4) Item Name, Description, Part Number/(CAGEC)	(5) U/I
5	C	7920-00-205-1711	Rag, Wiping, Cotton And Cotton Synthetic A-A-531 (81349)	GL
6	C	8030-00-889-3534	Tape, Antiseizing AA58092-2-1(58536)	ROLL

**OPERATOR AND FIELD MAINTENANCE
3K & 5K SEMI-TRAILER MOUNTED FABRIC TANK (SMFT), WATER
MANDATORY REPLACEMENT PARTS LIST**

INTRODUCTION

This work package includes a list of all mandatory replacement parts referenced in the task initial setups and procedures. These items must be replaced during maintenance, whether they have failed or not. This includes items based on usage intervals such as miles, time, rounds fired, etc.

MANDATORY REPLACEMENT PARTS LIST**Table 1. Mandatory Replacement Parts List**

Item No.	Part Number/ (CAGEC)	National Stock Number (NSN)	Nomenclature	Qty
1	H2525M (81718)	5310-00-637-9541	LOCK WASHER	16
2	FCB-62398 (05476)	5330-01-262-5120	GASKET	2
3	AA59326-9 (58536)	5330-00-899-4509	GASKET	2
4	AS3578-383 (81343)	5331-00-364-9862	O-RING	1
5	AA59326-G6 (58536)	5330-00-612-2414	GASKET	2
6	600-0002-1/2 (83259)	5330-01-525-8494	PACKING W/RETAINER	6

END OF WORK PACKAGE

INDEX

<u>Subject</u>	<u>WP Sequence No.-Page No.</u>
A	
Assembly and Preparation for Use.....	0012-3
B	
Basic Issue Item (BII) Lists, Components of End Item (COEI) and.....	0032-3
C	
Components of End Item (COEI) and Basic Issue Item (BII) Lists.....	0032-2
Corrosion Prevention and Control (CPC).....	0001-1
D	
Description and Use of Operator Controls and Indicators.....	0004-1
Destruction of Army Materiel To Prevent Enemy Use.....	0001-2
Differences Between Models.....	0002-3
Draining Tank	0005-4, 0012-11
E	
Emergency Repair of Tank.....	0011-1
Equipment Characteristics, Capabilities and Features.....	0002-1
Equipment Data.....	0002-3
Equipment Used With Tank.....	0002-2
Expendable and Durable Items List.....	0033-1
F	
Field Troubleshooting Procedures.....	0008-1
Filler/Discharge Assembly Maintenance	0013-1
Filler/Discharge Assembly RPSTL	0021-1
Filling The Tank	0012-7
G	
General Information.....	0001-1
H	
Hose Assembly Maintenance.....	0016-1
Hose Assembly, Four Inch RPSTL.....	0024-1
Hose Assembly, Two Inch RPSTL	0025-1
How To Use This Manual	iv

INDEX

<u>Subject</u>	<u>WP Sequence No.-Page No.</u>
I	
Information Data Plates	0002-3
Inspection Plate Maintenance	0014-1
Inspection Plate RPSTL	0022-1
Interim NBC Decontamination Procedures	0006-2
J, K	
L	
Leakage Definitions	0009-1
List of Abbreviations/Acronyms	0001-2
Location and Description of Major Components	0002-1
M	
Maintenance Allocation Chart (MAC) Introduction	0030-1
Maintenance Allocation Chart (MAC)	0031-1
Maintenance Forms, Records and Reports.....	0001-1
Mandatory Replacement Parts List	0034-1
N	
National Stock Number Index.....	0027-1
Nozzle Assembly Maintenance	0017-1
Nozzle Assembly RPSTL	0026-1
O	
Operation In Extreme Cold	0006-1
Operation In Extreme Heat.....	0006-1
Operation In High Wind	0006-1
Operation In Mud	0006-1
Operation In Rain.....	0006-2
Operation In Salt Water Areas.....	0006-1
Operation In Sandy or Dusty Conditions	0006-1
Operation Under Unusual Conditions.....	0006-1
Operation Under Usual Conditions.....	0005-1
Operator Troubleshooting Procedures	0007-1
Operator's PMCS Procedures	0010-1
Operator's Preventive Maintenance Checks and Services (PMCS) Introduction	0009-1

INDEX

Subject WP Sequence No.-Page No.

P

Part Number Index..... 0028-1
 Preparation for Movement..... 0005-3, 0012-10
 Preparation for Storage or Shipment..... 0001-2
 Preventive Maintenance Checks and Services (PMCS) Introduction 0009-1
 Preventive Maintenance Checks and Services (PMCS) Procedures..... 0010-1
 Principles of Operation 0003-1

Q

R

References 0029-1
 Relief Valve RPSTL 0023-1
 Repacking..... 0012-12
 Repair Parts and Special Tools List (RPSTL) Introduction 0018-1
 Reporting Equipment Improvement Recommendations (EIR)..... 0001-1

S

Scope 0001-1
 Service Upon Receipt..... 0012-1

T

Tank Envelope RPSTL 0020-1
 Tank Fabric, Collapsible RPSTL 0019-1
 Theory of Operation..... 0002-1

U

Unpacking 0012-1

V

Valve Cap and Core Maintenance..... 0015-1

W

Warning Summary..... a

X, Y, Z

RECOMMENDED CHANGES TO PUBLICATIONS AND BLANK FORMS For use of this form, see AR 25-30; the proponent agency is ODISC4.						Use Part II (reverse) for Repair Parts and Special Tool Lists (RPSTL) and Supply Catalogs/Supply Manuals (SC/SM).	DATE Date you filled out this form.
TO: <i>(Forward to proponent of publication or form) (Include ZIP Code)</i> U.S. Army TACOM Life Cycle Management Command ATTN: AMSTA-LC-LMP/TECH PUBS 1 Rock Island Arsenal, Rock Island, IL 61299-7630						FROM: <i>(Activity and location) (Include ZIP Code)</i> Your mailing address	
PART I – ALL PUBLICATIONS (EXCEPT RPSTL AND SC/SM) AND BLANK FORMS							
PUBLICATION/FORM NUMBER TM 10-5430-256-13&P				DATE 15 April 2009		Title Oper & Field Maint Manual w/RPSTL for 3K & 5K SMFT, Water Collapsible, Models GTA-3K-SMFT and GTA-5K-SMFT	
ITEM NO.	PAGE NO.	PARA-GRAPH	LINE NO. *	FIGURE NO.	TABLE NO.	RECOMMENDED CHANGES AND REASON (Provide exact wording of recommended changes, if possible).	
SAMPLE							
<i>*Reference to line numbers within the paragraph or subparagraph.</i>							
TYPED NAME, GRADE OR TITLE <i>Your Name</i>				TELEPHONE EXCHANGE/AUTOVON, PLUS EXTENSION		Signature <i>Your Signature</i>	

TO: (Forward direct to addressee listed in publication) U. S. Army TACOM Life Cycle Management Command ATTN: AMSTA-LC-LMPP/TECH PUBS 1 Rock Island Arsenal, Rock Island, IL 61299-7630	FROM: (Activity and location) (Include ZIP Code) Your address	DATE Date you filled out this form
--	---	--

PART II – REPAIR PARTS AND SPECIAL TOOL LISTS AND SUPPLY CATALOGS/SUPPLY MANUALS

PUBLICATION NUMBER TM 10-5430-256-13&P	DATE 15 April 2009	TITLE Oper & Field Maint Manual w/RPSTL for 3K & 5K SMFT, GTA-3K-SMFT & GTA-5K-SMFT
---	-----------------------	--

PAGE NO.	COLM NO.	LINE NO.	NATIONAL STOCK NUMBER	REFERENCE NO.	FIGURE NO.	ITEM NO.	TOTAL NO. OF MAJOR ITEMS SUPPORTED	RECOMMENDED ACTION
SAMPLE								

PART III – REMARKS (Any general remarks or recommendations, or suggestions for improvement of publications and blank forms. Additional blank sheets may be used if more space is needed.)

TYPED NAME, GRADE OR TITLE Your Name	TELEPHONE EXCHANGE/AUTOVON, PLUS EXTENSION	SIGNATURE Your Signature
---	--	-----------------------------

TO: (Forward direct to addressee listed in publication) U. S. Army TACOM Life Cycle Management Command ATTN: AMSTA-LC-LMPP/TECH PUBS 1 Rock Island Arsenal, Rock Island, IL 61299-7630	FROM: (Activity and location) (Include ZIP Code)	DATE
--	---	-------------

PART II – REPAIR PARTS AND SPECIAL TOOL LISTS AND SUPPLY CATALOGS/SUPPLY MANUALS

PUBLICATION NUMBER TM 10-5430-256-13&P				DATE 15 April 2009			TITLE Oper & Field Maint Manual w/RPSTL for 3K & 5K SMFT, GTA-3K-SMFT & GTA-5K-SMFT	
PAGE NO.	COLM NO.	LINE NO.	NATIONAL STOCK NUMBER	REFERENCE NO.	FIGURE NO.	ITEM NO.	TOTAL NO. OF MAJOR ITEMS SUPPORTED	RECOMMENDED ACTION

PART III – REMARKS (Any general remarks or recommendations, or suggestions for improvement of publications and blank forms. Additional blank sheets may be used if more space is needed.)

TYPED NAME, GRADE OR TITLE	TELEPHONE EXCHANGE/AUTOVON, PLUS EXTENSION	SIGNATURE
----------------------------	--	-----------

RECOMMENDED CHANGES TO PUBLICATIONS AND BLANK FORMS						Use Part II (reverse) for Repair Parts and Special Tool Lists (RPSTL) and Supply Catalogs/Supply Manuals (SC/SM).	DATE
For use of this form, see AR 25-30; the proponent agency is ODISC4.							
TO: (Forward to proponent of publication or form) (Include ZIP Code) U. S. Army TACOM Life Cycle Management Command ATTN: AMSTA-LC-LMPP/TECH PUBS 1 Rock Island Arsenal, Rock Island, IL 61299-7630				FROM: (Activity and location) (Include ZIP Code)			
PUBLICATION/FORM NUMBER TM 10-5430-256-13&P						DATE 15 April 2009	TITLE Oper & Field Maint Manual w/RPSTL for 3K & 5K SMFT Water Collapsible, GTA-3K-SMFT and GTA-5K-SMFT
ITEM NO.	PAGE NO.	PARA-GRAPH	LINE NO. *	FIGURE NO.	TABLE NO.	RECOMMENDED CHANGES AND REASON (Provide exact wording of recommended changes, if possible).	
<i>*Reference to line numbers within the paragraph or subparagraph.</i>							
TYPED NAME, GRADE OR TITLE				TELEPHONE EXCHANGE/AUTOVON, PLUS EXTENSION		SIGNATURE	

TO: (Forward direct to addressee listed in publication) U. S. Army TACOM Life Cycle Management Command ATTN: AMSTA-LC-LMPP/TECH PUBS 1 Rock Island Arsenal, Rock Island, IL 61299-7630	FROM: (Activity and location) (Include ZIP Code)	DATE
--	---	-------------

PART II – REPAIR PARTS AND SPECIAL TOOL LISTS AND SUPPLY CATALOGS/SUPPLY MANUALS

PUBLICATION NUMBER TM 10-5430-256-13&P				DATE 15 April 2009			TITLE Oper & Field Maint Manual w/RPSTL for 3K & 5K SMFT, GTA-3K-SMFT & GTA-5K-SMFT	
PAGE NO.	COLM NO.	LINE NO.	NATIONAL STOCK NUMBER	REFERENCE NO.	FIGURE NO.	ITEM NO.	TOTAL NO. OF MAJOR ITEMS SUPPORTED	RECOMMENDED ACTION

PART III – REMARKS *(Any general remarks or recommendations, or suggestions for improvement of publications and blank forms. Additional blank sheets may be used if more space is needed.)*

TYPED NAME, GRADE OR TITLE	TELEPHONE EXCHANGE/AUTOVON, PLUS EXTENSION	SIGNATURE
----------------------------	--	-----------

TM 10-5430-256-13&P

By Order of the Secretary of the Army:

Official:

A handwritten signature in black ink that reads "Joyce E. Morrow". The signature is written in a cursive style with a large initial "J" and "M".

JOYCE E. MORROW
*Administrative Assistant to the
Secretary of the Army*

0909004

GEORGE W. CASEY, JR.
*General, United States Army
Chief of Staff*

DISTRIBUTION: To be distributed in accordance with the initial distribution number (IDN) 256998, requirements for TM 10-5430-256-13&P.

The Metric System and Equivalents

Linear Measure

1 centimeter = 10 millimeters = .39 inch
 1 decimeter = 10 centimeters = 3.94 inches
 1 meter = 10 decimeters = 39.37 inches
 1 dekameter = 10 meters = 32.8 feet
 1 hectometer = 10 dekameters = 328.08 feet
 1 kilometer = 10 hectometers = 3,280.8 feet

Weights

1 centigram = 10 milligrams = .15 grain
 1 decigram = 10 centigrams = 1.54 grains
 1 gram = 10 decigrams = .035 ounce
 1 dekagram = 10 grams = .35 ounce
 1 hectogram = 10 dekagrams = 3.52 ounces
 1 kilogram = 10 hectograms = 2.2 pounds
 1 quintal = 100 kilograms = 220.46 pounds
 1 metric ton = 10 quintals = 1.1 short tons

Liquid Measure

1 centiliter = 10 milliliters = .34 fl. ounce
 1 deciliter = 10 centiliters = 3.38 fl. ounces
 1 liter = 10 deciliters = 33.81 fl. ounces
 1 dekaliter = 10 liters = 2.64 gallons
 1 hectoliter = 10 dekaliters = 26.42 gallons
 1 kiloliter = 10 hectoliters = 264.18 gallons

Square Measure

1 sq. centimeter = 100 sq. millimeters = .155 sq. inch
 1 sq. decimeter = 100 sq. centimeters = 15.5 sq. inches
 1 sq. meter (centare) = 100 sq. decimeters = 10.76 sq. feet
 1 sq. dekameter (are) = 100 sq. meters = 1,076.4 sq. feet
 1 sq. hectometer (hectare) = 100 sq. dekameters = 2.47 acres
 1 sq. kilometer = 100 sq. hectometers = .386 sq. mile

Cubic Measure

1 cu. centimeter = 1000 cu. millimeters = .06 cu. inch
 1 cu. decimeter = 1000 cu. centimeters = 61.02 cu. lathes
 1 cu. meter = 1000 cu. decimeters = 35.31 feet

Approximate Conversion Factors

<i>To change</i>	<i>To</i>	<i>Multiply by</i>	<i>To change</i>	<i>To</i>	<i>Multiply by</i>
inches	centimeters	2.540	ounce-inches	newton-meters	.007062
feet	meters	.305	centimeters	inches	.394
yards	meters	.914	meters	feet	3.280
miles	kilometers	1.609	meters	yards	1.094
square inches	square centimeters	6.451	kilometers	miles	.621
square feet	square meters	.093	square centimeters	square inches	.155
square yards	square meters	.836	square meters	square feet	10.764
square miles	square kilometers	2.590	square meters	square yards	1.196
acres	square hectometers	.405	square kilometers	square miles	.386
cubic feet	cubic meters	.028	square hectometers	acres	2.471
cubic yards	cubic meters	.765	cubic meters	cubic feet	35.315
fluid ounces	milliliters	29.573	cubic meters	cubic yards	1.308
pints	liters	.473	milliliters	fluid ounces	.034
quarts	liters	.946	liters	pints	2.113
gallons	liters	3.785	liters	quarts	1.057
ounces	grams	28.349	liters	gallons	.264
pounds	kilograms	.454	grams	ounces	.035
short tons	metric tons	.907	metric tons	short tons	1.102
pound-feet	newton-meters	1.356	kilograms	pounds	2.205
pound-inches	newton-meters	.11296			

Temperature (Exact)

°F Fahrenheit temperature

5/9 (after subtracting 32)

°C Celsius temperature

PIN: 085370-000